

ESSENTIAL ● ● ●

# Computer Hardware

The Illustrated Guide to Understanding  
Computer Hardware

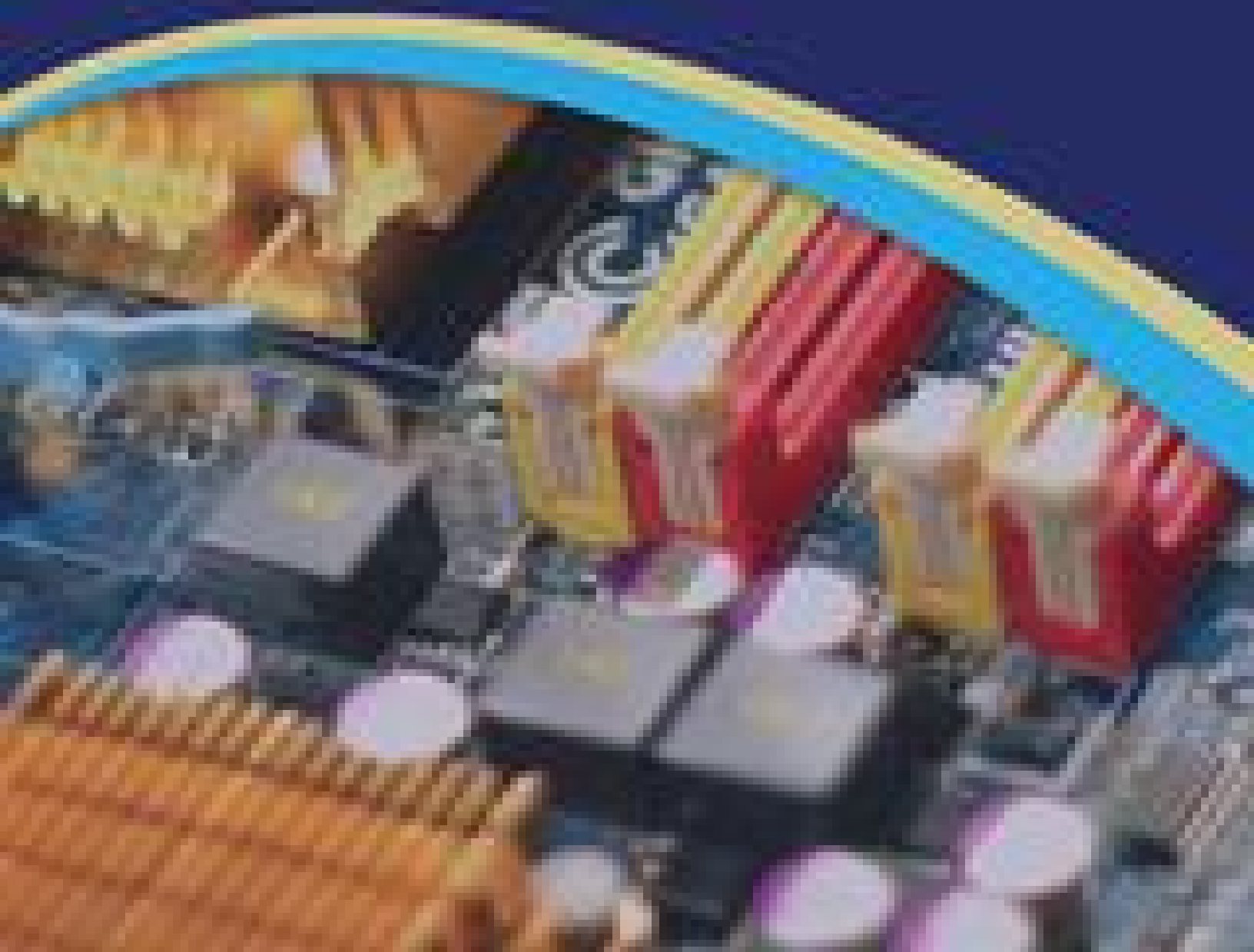

# **Essential Computer Hardware**

**Kevin Wilson**

# Essential Computer Hardware

Copyright © 2017 Elluminet Press

This work is subject to copyright. All rights are reserved by the Publisher, whether the whole or part of the material is concerned, specifically the rights of translation, reprinting, reuse of illustrations, recitation, broadcasting, reproduction on microfilms or in any other physical way, and transmission or information storage and retrieval, electronic adaptation, computer software, or by similar or dissimilar methodology now known or hereafter developed. Exempted from this legal reservation are brief excerpts in connection with reviews or scholarly analysis or material supplied specifically for the purpose of being entered and executed on a computer system, for exclusive use by the purchaser of the work. Duplication of this publication or parts thereof is permitted only under the provisions of the Copyright Law of the Publisher's location, in its current version, and permission for use must always be obtained from the Publisher. Permissions for use may be obtained through Rights Link at the Copyright Clearance Centre. Violations are liable to prosecution under the respective Copyright Law.

Trademarked names, logos, and images may appear in this book. Rather than use a trademark symbol with every occurrence of a trademarked name, logo, or image we use the names, logos, and images only in an editorial fashion and to the benefit of the trademark owner, with no intention of infringement of the trademark.

The use in this publication of trade names, trademarks, service marks, and similar terms, even if they are not identified as such, is not to be taken as an expression of opinion as to whether or not they are subject to proprietary rights.

While the advice and information in this book are believed to be true and accurate at the date of publication, neither the authors nor the editors nor the publisher can accept any legal responsibility for any errors or omissions that may be made. The publisher makes no warranty, express or implied, with respect to the material contained herein.

Publisher: Elluminet Press

Director: Kevin Wilson

Lead Editor: Steven Ashmore

Technical Reviewer: Mike Taylor, Robert Ashcroft

Copy Editors: Joanne Taylor, James Marsh

Proof Reader: Mike Taylor

Indexer: James Marsh

Cover Designer: Kevin Wilson

eBook versions and licenses are also available for most titles. Any source code or other supplementary materials referenced by the author in this text is available to readers at

[www.elluminetpress.com/resources](http://www.elluminetpress.com/resources)

For detailed information about how to locate your book's source code, go to

[www.elluminetpress.com/resources](http://www.elluminetpress.com/resources)

# About the Author

Kevin Wilson has made a career out of technology and showing others how to use it. After earning a master's degree in computer science, software engineering, and multimedia systems, Kevin worked as a tutor and college instructor, helping students master such subjects as multimedia, computer literacy and information technology. He currently serves as Elluminet Press Publishing's senior writer and director, he periodically teaches computing at college in South Africa and serves as an IT trainer in England.

Kevin's motto is clear: "If you can't explain something simply, you haven't understood it well enough." To that end, he has created the Computer Essentials series, in which he breaks down complex technological subjects into smaller, easy-to-follow steps that students and ordinary computer users can put into practice.

# Table of Contents

[Essential Computer Hardware&#9;2](#)

[About the Author&#9;3](#)

[Table of Contents&#9;4](#)

[General Concepts&#9;8](#)

[Types of Hardware&#9;8](#)

[Internal Hardware&#9;8](#)

[Basic Peripherals&#9;9](#)

[Basic Operating Systems&#9;10](#)

[Hardware Components&#9;12](#)

[Memory \(RAM\)&#9;12](#)

[Hard Disk Drive \(HDD\)&#9;16](#)

[Solid State Drive \(SSD\)&#9;18](#)

[CD/DVD/Blu-ray Drive&#9;18](#)

[Memory Cards&#9;19](#)

[USB Flash Drives&#9;21](#)

[External Hard Disk&#9;22](#)

[NAS Drives &#9;22](#)

[Personal Cloud&#9;23](#)

[Storage Units&#9;28](#)

[CPU / Processor&#9;29](#)

[Sound Card&#9;30](#)

[Video Card&#9;31](#)

[Expansion Slots&#9;32](#)

[Inside the Case&#9;33](#)

[Computer Peripherals&#9;36](#)

[Inkjet Printer&#9;36](#)

[Laser Printer&#9;37](#)

[USB&#9;40](#)

[Ethernet&#9;41](#)

[FireWire&#9;41](#)

[ThunderBolt&#9;42](#)

[eSATA&#9;42](#)

[DVI&#9;43](#)

[HDMI&#9;44](#)

[VGA &#9;44](#)

[Component Video&#9;45](#)

[Composite Video&#9;45](#)

[1/8" \(3.5mm\) Phono Jack&#9;46](#)

[1/4" \(6.35mm\) Phono Jack&#9;46](#)

[3 Pin XLR&#9;47](#)

[RCA Audio&#9;47](#)

[S/PDIF Optical Audio&#9;48](#)

[Types of Computer&#9;50](#)

[Desktop Computer&#9;50](#)

[Desktop: All-in-one&#9;51](#)

[Laptop &#9;52](#)

[Netbook&#9;53](#)

[Chrome Book&#9;54](#)

[Tablet Computers&#9;55](#)

[Hybrids&#9;56](#)

[Mainframe Computer&#9;57](#)

[Super Computer&#9;58](#)

[Understanding Hardware Specifications&#9;60](#)

[So Many Machines&#9;60](#)

[Mac or PC?&#9;61](#)

[Decoding Computer Specs&#9;63](#)

[Printer Specs&#9;64](#)

[The Internet&#9;66](#)

[DSL&#9;66](#)

[Fibre Optic&#9;67](#)

[Cable&#9;69](#)

[Satellite&#9;70](#)

[3G/4G&#9;70](#)

[WiFi&#9;72](#)

[Dual Band or Single Band?&#9;72](#)

[WiFi Extenders&#9;72](#)

[Wireless Standards&#9;73](#)

[Wireless Security&#9;73](#)

[Understanding Router Specifications&#9;74](#)

[Data Transfer Rates&#9;75](#)

[\*Bytes and Bits&#9;75\*](#)

[Computer Networks&#9;78](#)

[Local Area Networks \(LANs\)&#9;78](#)

[Metropolitan Area Networks \(MANs\)&#9;79](#)

[Wide Area Networks \(WANs\)&#9;80](#)

[Peer-to-peer Network &#9;81](#)

[Client-server Network&#9;82](#)

[Ethernet&#9;83](#)

[Cellular Network&#9;85](#)

[Bluetooth&#9;86](#)

[Cloud Computing and the Web&#9;88](#)

[Computer Software&#9;92](#)

[The Operating System&#9;92](#)

[Apps & Applications&#9;94](#)

[Windows File Management&#9;96](#)

[Creating Folders&#9;99](#)

[Moving Files&#9;99](#)

[Copying Files&#9;100](#)

[Compress Files&#9;101](#)

[Searching for Files&#9;102](#)

[System Maintenance&#9;103](#)

[Anti-Virus Software&#9;104](#)

[Windows Defender&#9;104](#)

[Avast&#9;104](#)

[AVG&#9;106](#)

[Backing Up your Files&#9;106](#)

[Restoring Files&#9;109](#)

[Windows Update&#9;110](#)

[Disk De-fragmentation&#9;111](#)

[Disk Clean-Up&#9;113](#)

[Start-Up Programs&#9;114](#)

[Remove Programs and Apps&#9;115](#)

[System Recovery&#9;119](#)

[Advanced Start up&#9;121](#)

[Create a Recovery Drive&#9;122](#)



# General Concepts

The term Information Technology refers to the use of computers to process and display data. Computers are now commonly used to communicate with other people and performing tasks such as word processing, calculations and multimedia.

In order for a computer to work it needs two things – hardware and software.

The hardware is the physical part, such as the keyboard, monitor or printer – the bits you can touch in other words.

The software is part that runs on the hardware, ie the tools you use to perform tasks such as word processing. The software would be Microsoft Word.

# **Types of Hardware**

On a desktop computer, the case houses all the internal hardware, such as CPU, RAM and Hard disks. Peripherals sit outside the case, and the Operating System runs on the internal hardware.

# Internal Hardware

These are the three primary components. We'll go into more detail in later chapters, but for now here is an overview.



These are all mounted onto a main circuit board, called a motherboard.

# Basic Peripherals

The most common peripherals are

- Monitors
- Printers
- Keyboards
- Mice
- Scanners
- Cameras

These all sit outside the case and connect to your computer via USB cable or similar.

Some familiar ones are pictured below.



# Basic Operating Systems

As well as all the hardware and peripherals, you need software to make the computer work. The first piece of software that is needed is called an Operating System.

This could be...

- Windows 10 on a PC
- Mac OS if you're on a Mac Computer.

These look similar to the ones pictured below

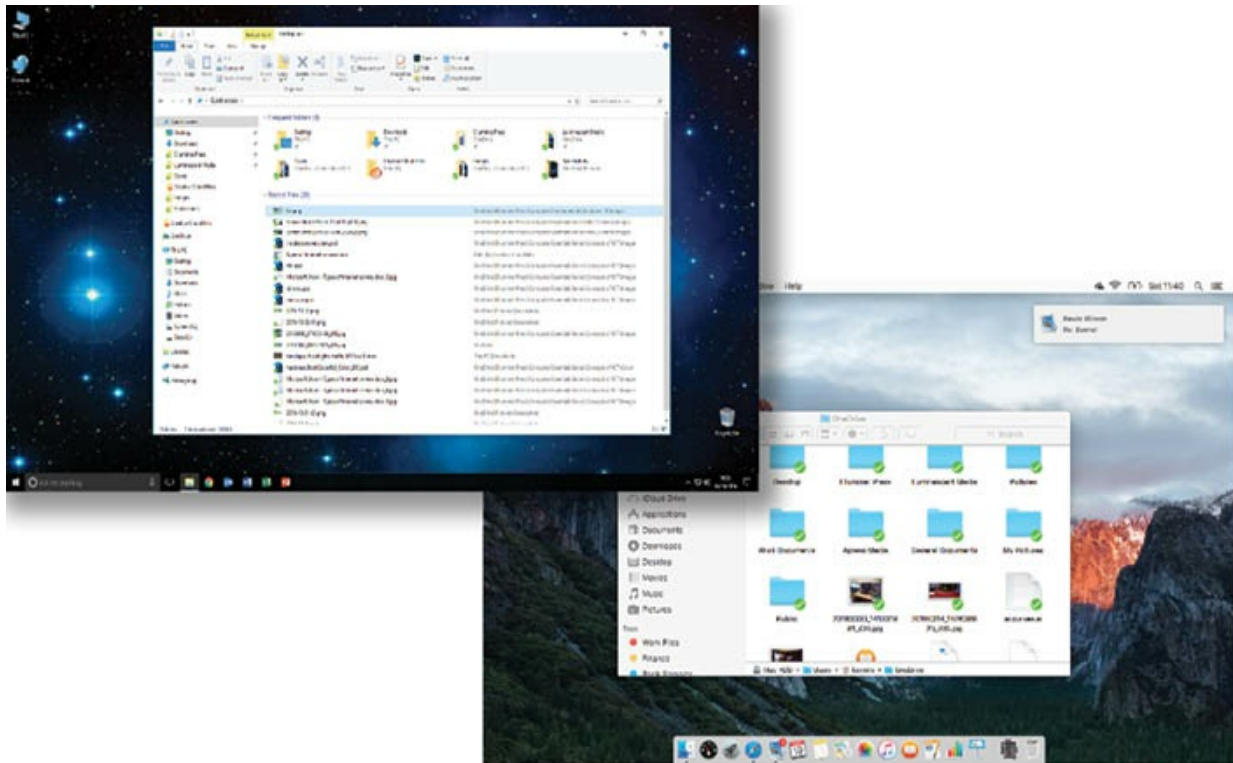

This Operating System provides you with a user interface where you can use various tools called programs or software to do your work. For example, Microsoft Office is a software application package that allows you to create documents, presentations, spreadsheets and so on. Photoshop is a program for editing photos.

# Hardware Components

Computer systems are made up of a number of different hardware components such as a central processor (CPU), memory (RAM), storage space (HDD) and so on. This is called internal hardware and usually plugs into a main board called a motherboard.

Devices that sit outside the case are called peripherals and can include printers, scanners, keyboards, mice, cameras and so on.

There is also removable storage such as memory cards, USB sticks and external hard drives that are designed to be portable.

Lets start by taking a look at internal hardware.

# Memory ( RAM)

Computer memory is made up of silicon chips and is the computer's working area. This is where software instructions and data are stored.



For example if you are typing a document in Microsoft Word, both Microsoft Word and your document are loaded into and stored in the computer's memory while you are working on it. This is not to be confused with the Hard Disk. Usually measured in GigaBytes

DRAM or Dynamic Ram needs to be constantly refreshed. SRAM or static RAM is a lot faster because it doesn't require to be refreshed.

Standard system RAM is DRAM or sDRAM. SRAM is reserved for cache memory and is mounted onto the motherboard already.

To confuse things even more, RAM comes in different forms: DDR, DDR2, DDR3 and DDR4.



DDR and DDR2 are old now and being phased out in favour of DDR3 and DDR4. Most of the latest PCs will use DDR3 & DDR4 RAM.

Notice the positions of the cut out notches along the bottom of the DIMM indicated in red on the photograph above. This is to make sure only the correct RAM fits in the slot on the motherboard.

RAM speed is also measured in MegaHertz (MHz) and you'll likely see this when looking at buying RAM.

Laptops have their own type of memory. It's more or less the same except for



the physical size. These memory modules are called SO-DIMMs

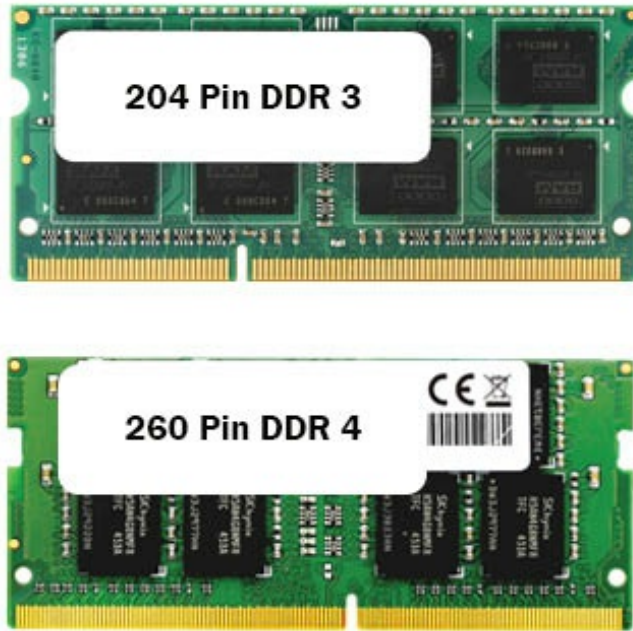

When buying memory, you need to find out what memory modules your computer's motherboard takes. You should be able to find this in the documentation that came with your computer.

So looking at the spec of my computer, shown below, I need a DDR4 memory module that runs at about 2133MHz.

Slots	Four DIMM sockets
Type	DDR4
Speed	<ul style="list-style-type: none"><li>• 2133 MHz</li><li>• Up to 2400 MHz with XMP (optional)</li></ul>
Configurations supported	4 GB, 8 GB, 16 GB, 32 GB, and 64 GB

Also reading further down, I can get 4, 8,16,32 or 64GB modules. For this example I am going to add 16GB

So when searching, I'll look for something the one shown below, and make sure the module is DDR4 and runs at least 2133MHz as it said in the PC's spec above.

Technical Details	
Brand	
Item Weight	41 g
Product Dimensions	13.3 x 3.1 x 0.3 cm
Item model number	HX421C14FBK2/16
Series	16GB 2133MHz DDR4 Kit of 2
Color	Black
Form Factor	288-pin DIMM
RAM Size	16 GB
Memory Technology	PC-17000, 288-pin DIMM, DDR4
Computer Memory Type	DDR4 SDRAM
Voltage	1.2 volts
Operating System	Yes
Software Included	Yes

Number of pins on the memory module, must be the same as your motherboard spec

Memory type: DDR, DDR2, DDR3 or DDR4. Needs to match the type of memory your motherboard requires

You will also need to open the case and find out how many memory slots are available.

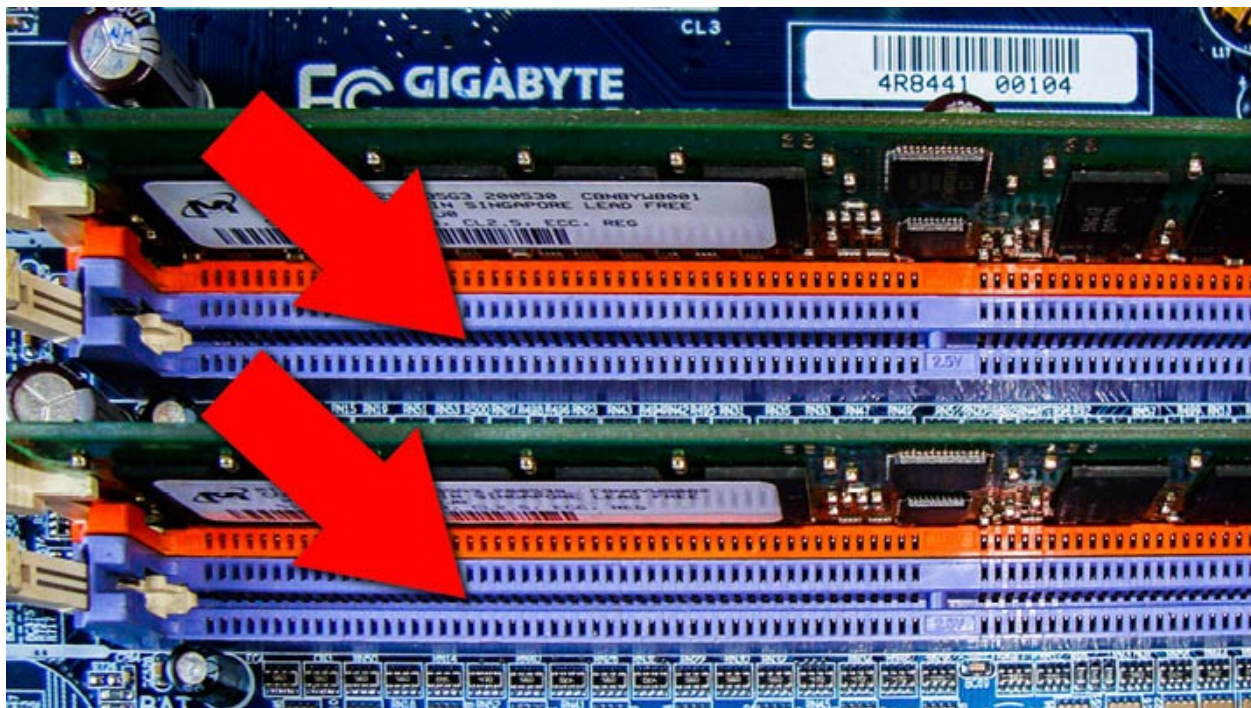

This one has two spare and two in use.

Slide the DIMM into a vacant slot, it will only go one way, then gently push down until it clicks into place.

# Hard Disk Drive ( HDD)

The hard disk (also called a hard drive) is like a filing cabinet and permanently stores all your documents, photographs, music, your operating system (such as Microsoft windows) and your installed software (such as Microsoft word)



When you start up an application such as Microsoft word, the Microsoft word software is loaded up off the hard disk into the computer's memory (or ram), where you can work on your documents. Usually measured in Gigabytes and Terabytes, eg 500GB, 1TB, 4TB.

The disk spins at 7200rpm on most modern hard disk drives and connects to your computer's motherboard using SATA.

Some cheaper drives run at 5400rpm and can be slow on modern computers, so keep this in mind when buying.

# Solid State Drive ( SSD)

Performs much like a Hard Disk but is extremely fast and also extremely expensive.



These drives are being used in smaller laptops/notebook computers and on some tablet computers where you don't require large amounts of storage space.

These drives can also be useful where you need fast data transfer rates, such as for video editing, playing games and recording audio/video.

These can be over 2TB, however large capacities are expensive. The average size in use is about 250GB

# CD/ DVD/ Blu-ray Drive

Another dying breed, this drive allows you to play CDs, watch DVDs or Blu-Ray movies that come on a disk.



You can also create your own. Most of these drives have a “writer” function that allows you to copy your own data onto a blank disk; this could be your photographs, documents or your home movies.





# Memory Cards

Memory cards are commonly used in digital cameras, tablets and some smart phones. The most common type are called SD Cards and come in a variety of sizes; SD, Mini SD and Micro SD, shown below.

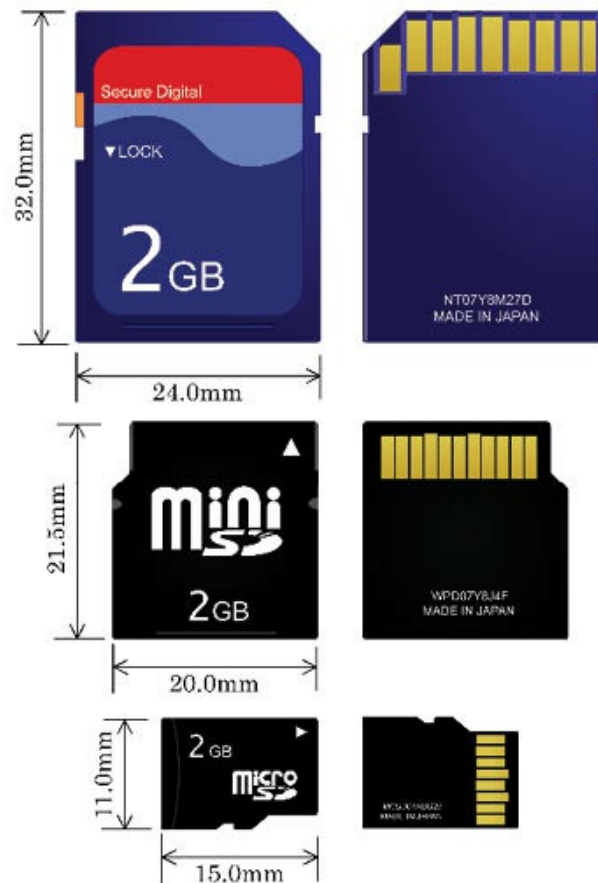

SD cards tend to be used in digital cameras, while mini and micro SD cards are used in smart phones and tablets.

These cards are usually read with a card reader. Most tablets and smart phones have these built in, however you can buy USB card readers that plug into your computer like the one below.



# USB Flash Drives

Also called memory sticks, these little things plug into the USB port on your computer or laptop and allow you to copy files onto them much like a hard disk.

They are more for backup and transport of data such as photos, documents etc.



These drives come in a variety of shapes and capacities ranging from 2GB up

to 512GB

# External Hard Disk

External hard disks are hard disk drives that sit outside the computer and plug into your USB port.



These are designed for portability and are usually small enough to fit in your pocket. These are great for backup and transport of data such as photos, documents, videos etc.

These can range up to about 4TB.

# NAS Drives

NAS drives, sometimes called Network Attached Storage, allow you to store and backup files to a central point on your home network.

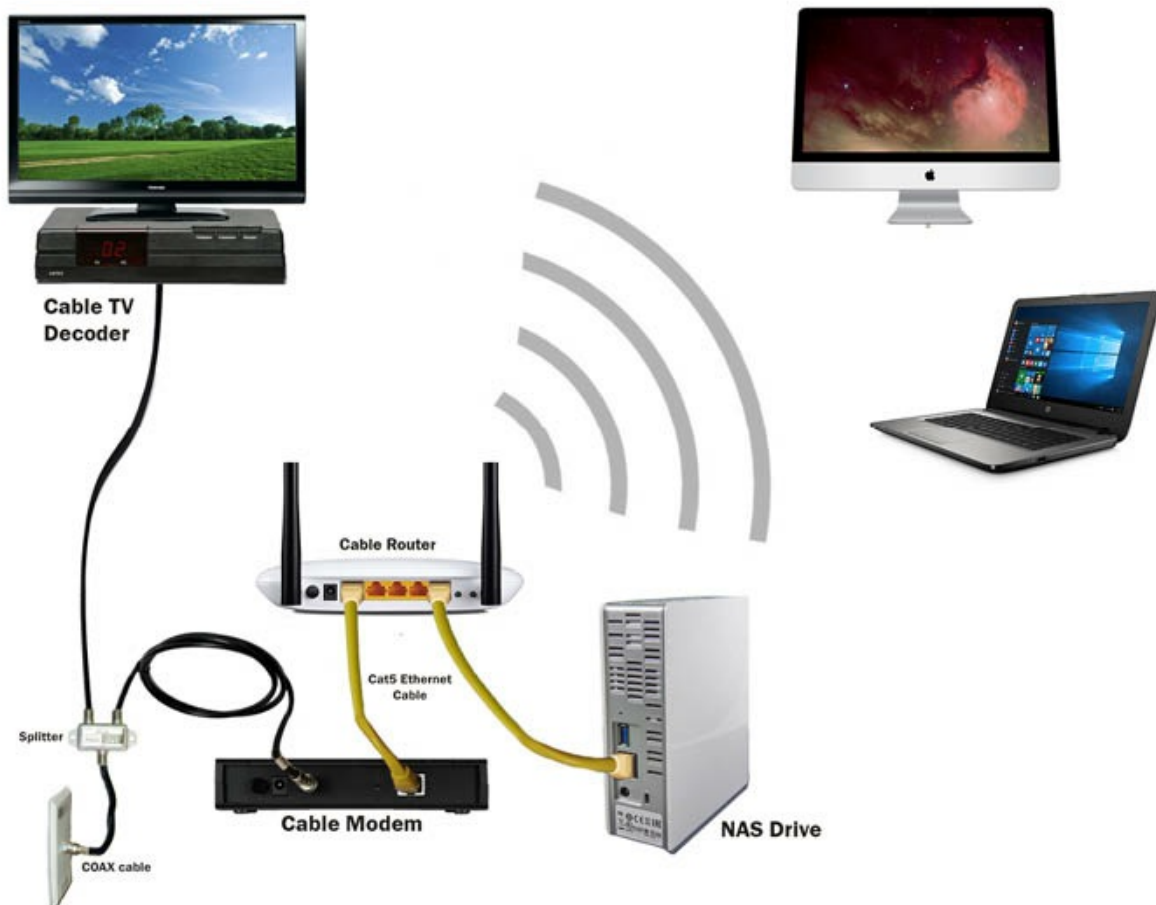

All the machines on the network can access files on the NAS drive, shared data can either be set to private for one particular machine or shared publicly for all machines to see.

These devices make great backup strategies and come with software you can install on your computer to automate backups at certain times.

You will need a few terabytes of storage on your NAS.

# Personal Cloud

Personal Cloud storage takes your NAS drive one step further. An example of this is Western Digital's 'My Cloud' device.

This device works like a NAS drive, as described above, except it will sync all your files to its cloud service on the internet, meaning you can access your files from anywhere, not just at home. To get started go to...

[www.mycloud.com/setup](http://www.mycloud.com/setup)

Click 'Get Started'; make sure your MyCloud device is powered on and connected to your router. Click next.

Select your device from the list, then click next.



Enter your name and email address for your MyCloud.com account

Connect > Personal Cloud > Setup Complete

### Set up your personal cloud

Enter your name to create your user account. You'll use this account to access your WD My Cloud from inside your home.

Kevin  Wilson \*Required

**Want to access your files from outside your home?**

Enter your email to create (or expand) your WD My Cloud account. You'll use this account to access your WD My Cloud from anywhere in the world. You'll receive an email with additional information and instructions.

(Optional)

Also register WD My Cloud with this information ⓘ

Click next.

On the next screen, it is useful to install the 'My Cloud application' as this will allow you to administer your personal cloud so you can easily change settings, create users, share files etc. Also placing a shortcut on the desktop makes it easy to launch the application, should you need to change any settings.

Connect > Personal Cloud > Setup Complete

## Congratulations! Your WD My Cloud is set up!

Next, we recommend installing the WD My Cloud application

**Install the WD My Cloud application**  
Easily access, upload, share, and manage your files on your personal cloud, whether you're at home or on the road.

Also:

- Place helpful aliases on my Desktop ⓘ
- Recommended: Automatically update WD My Cloud whenever new firmware becomes available

Click finish, when you're done.



Check your email and click on the confirmation link. Enter a MyCloud password for your account.

## Create MyCloud.com password

This password lets you access your content anywhere on any device.

Your email: **kevin.wilson@elluminetpress.com**

This password will also be used as your device password.

Sign into the MyCloud.com account to access files from MyCloud.com

Enter the password for a user account

Click 'Download WD sync' and allow it to install.

Once that is done, enter your username and password you created in previous steps.

Select any additional folders you would like to keep in sync with the My Cloud

## Sync your files

We selected the most common folders on your computer. Changes you make to these folders will be automatically made on your My Cloud drive.

	Name	Size
<input checked="" type="checkbox"/>	 Documents	3 GB
<input checked="" type="checkbox"/>	 Pictures	12.2 GB
<input checked="" type="checkbox"/>	 Music	10.2 GB
<input checked="" type="checkbox"/>	 Movies	67.2 GB

Next

WD Sync will begin scanning and syncing files. Depending on how many files you have on your computer, this could take a while.

You can access any of your files from  
[mycloud.com](http://mycloud.com)

Just click sign in and enter your username and password.

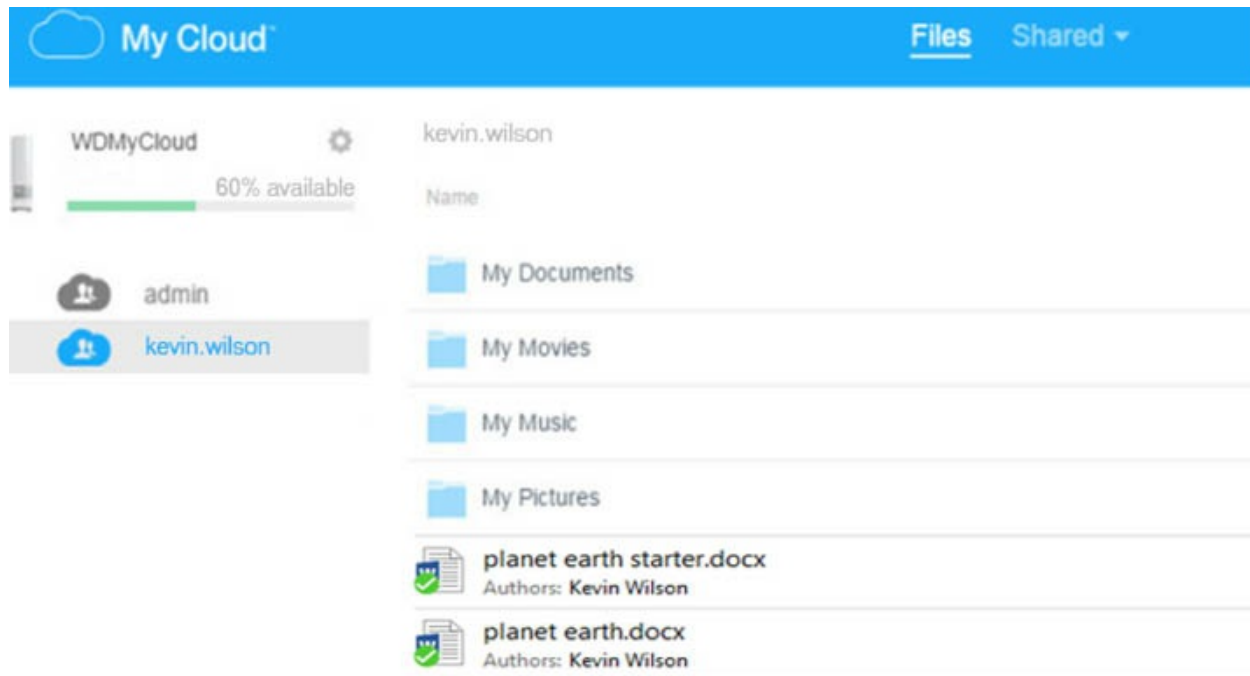

Here you can browse through your files, double click on the folders to open them.

To open documents, double click on the icons. This will open the file in the allocated application, in this case Microsoft Word.

This means you can log in and access your files from any computer or laptop connected to the internet

You can also download these files, email them or share them on social media.

You can also access your files on your phone or tablet. Just go to the appstore and download the app 'mycloud'

Launch the mycloud app then log in using your username and password. You'll be able to tap on any of the files and documents, share them, edit them and so on.

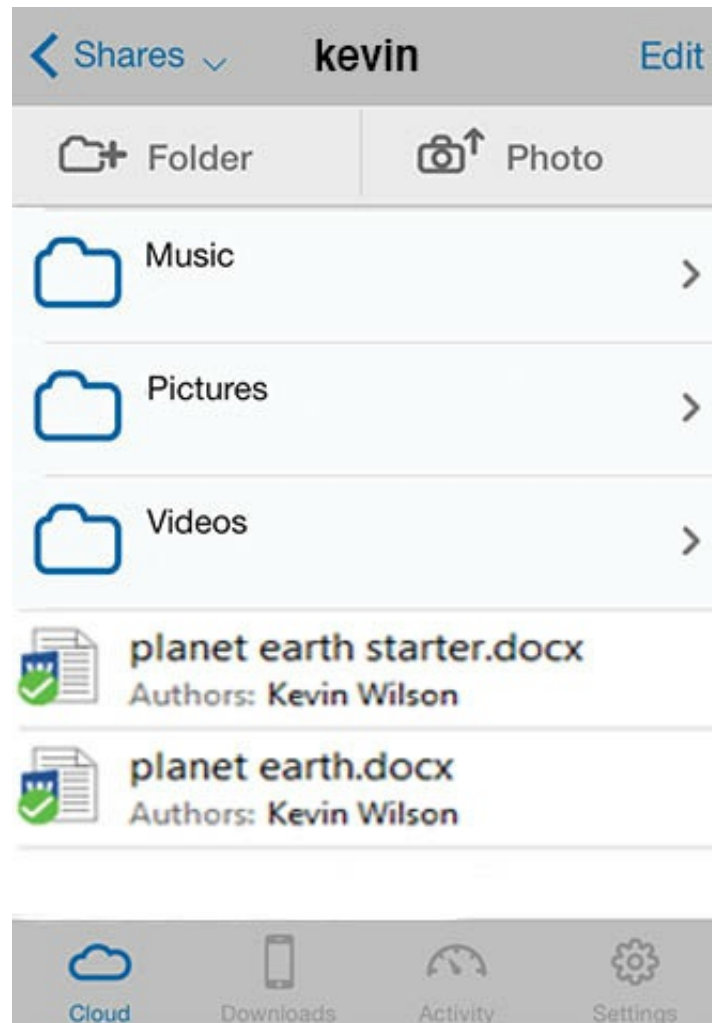

Makes a great backup device and also allows you to work from anywhere which is ideal for business users, college students, teachers and so on.

These are very similar to [dropbox.com](https://www.dropbox.com), [onedrive.com](https://onedrive.com), [googledrive](https://www.google.com/drive), etc.

# Storage Units

Much like length can be measured in metres and kilometres or weight in grams and kilograms, computer storage is measured in bytes and kilobytes.

For example, 1 kilobyte is rounded to 1000 bytes for ease of use.

Without getting too technical, it's exactly 1024 bytes in a kilobyte because computers use binary to count (2, 4, 8, 16, 32, 64, 128, 256, 512, 1024), not the decimal system (1, 10, 100, 1000, 10000, 100000) like we do.

If you remember from primary school maths, reading from right to left, you have your units, tens, hundreds, thousands and so on. So you can write a number 123 ( $3 + 20 + 100 = 123$ ).

Using binary it's the same, except you use 2s (reading from right to left 1, 2, 4, 8, 16, 32, 64, 128 and so on). So the number 123 in binary would be 1111011 ( $64 + 32 + 16 + 8 + 2 + 1 = 123$ )

In decimal	100	10	1							
	1	2	3	=						One 100 + Two 10s + Three 1s = 123
In binary	64	32	16	8	4	2	1			
	1	1	1	1	0	1	1	=		64 + 32 + 16 + 8 + 2 + 1 = 123

If you count a bit further in binary, you'll get to 128, 256, 512, 1024... So you see why it's 1024 not 1000.

Here's a summary of the different units you'll most likely come across when using computers.

Bit	Most basic unit of storage	Either a '1' or a '0'
Byte	Consists of 8 bits	a series of 8 bits is encoded to represent a character, number, etc
Kilo Byte	1024 Bytes	rounded to 1000 bytes
Mega Byte	1024 Kilo Bytes	rounded to 1,000,000 bytes
Giga Byte	1024 Mega Bytes	rounded to 1,000,000,000 bytes
Tera Byte	1024 Giga Bytes	rounded to 1,000,000,000,000 bytes

To give you an idea, music and photos can be a couple of mega bytes each but can take up a few hundred gigabytes if you have a lot. Large documents can be around 40 megabytes, or about 50 kilo bytes if they are short.

# CPU / Processor

The CPU or processor is the brain of the computer and responds to all the commands you give the computer. It is one of the primary factors in determining the power of the system. Measured in Gigahertz, the higher the number, the more powerful the processor.



Modern processors have multiple cores. You might see a dual core or quad core processor. A core is an independent processing unit, meaning the processor can execute more than one instruction at a time, so the more cores your processor has, theoretically the faster it is.

The operation of most CPUs, is to execute a sequence of stored instructions called a program. The instructions are kept in the computer's memory (or RAM).

There are four steps that nearly all CPUs use in their operation:

fetch, decode, execute, writeback.

Processors running at 2Ghz or more, do this billions of times a second.

# Sound Card

A sound card also known as an audio card is an internal expansion card, that facilitates the input and output of audio signals to and from a computer, providing the audio for multimedia applications such as music, editing video or audio, presentations, games and video projection; through a speaker or sound system.

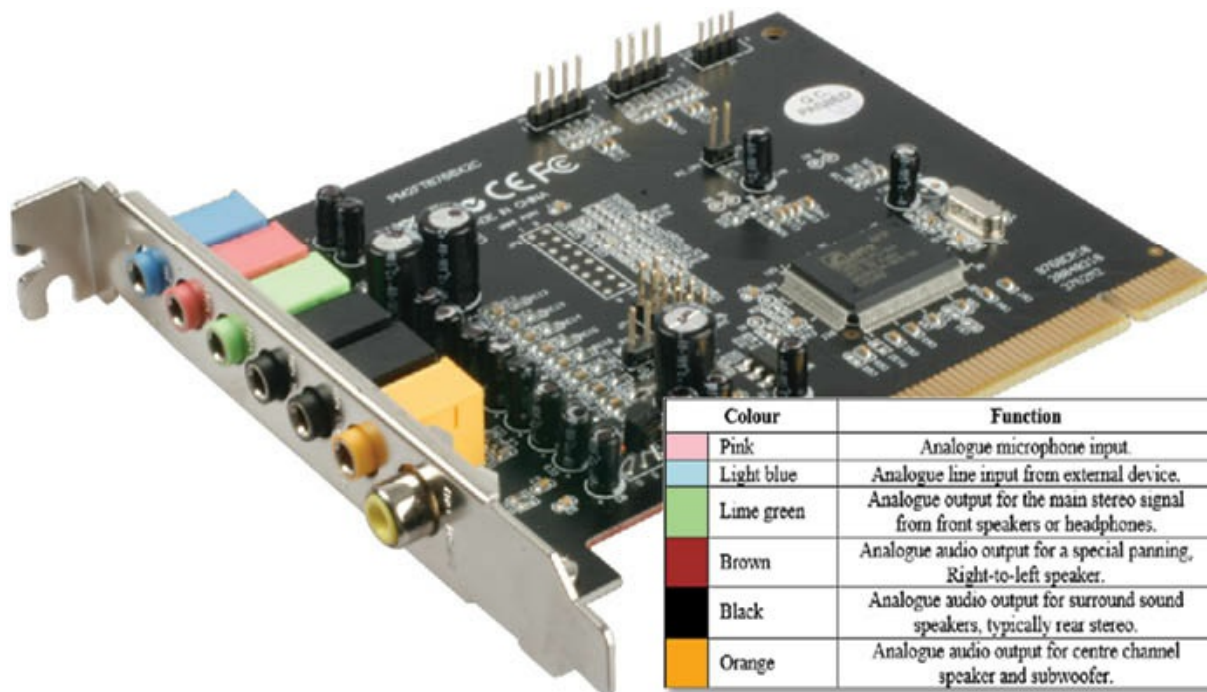

Sound cards are usually integrated into most modern motherboards, using basically the same components as a plug-in card.

The best plug-in cards, which use better and more expensive components, can achieve higher quality than integrated sound and are usually used in higher end applications such as audio production, music composition and video editing.

Some sound cards have more specialist connections such as digital output for connecting to sound systems and amplifiers.



# Video Card

The video card or graphics card is responsible for processing video, graphic and visual effects you see on your monitor.

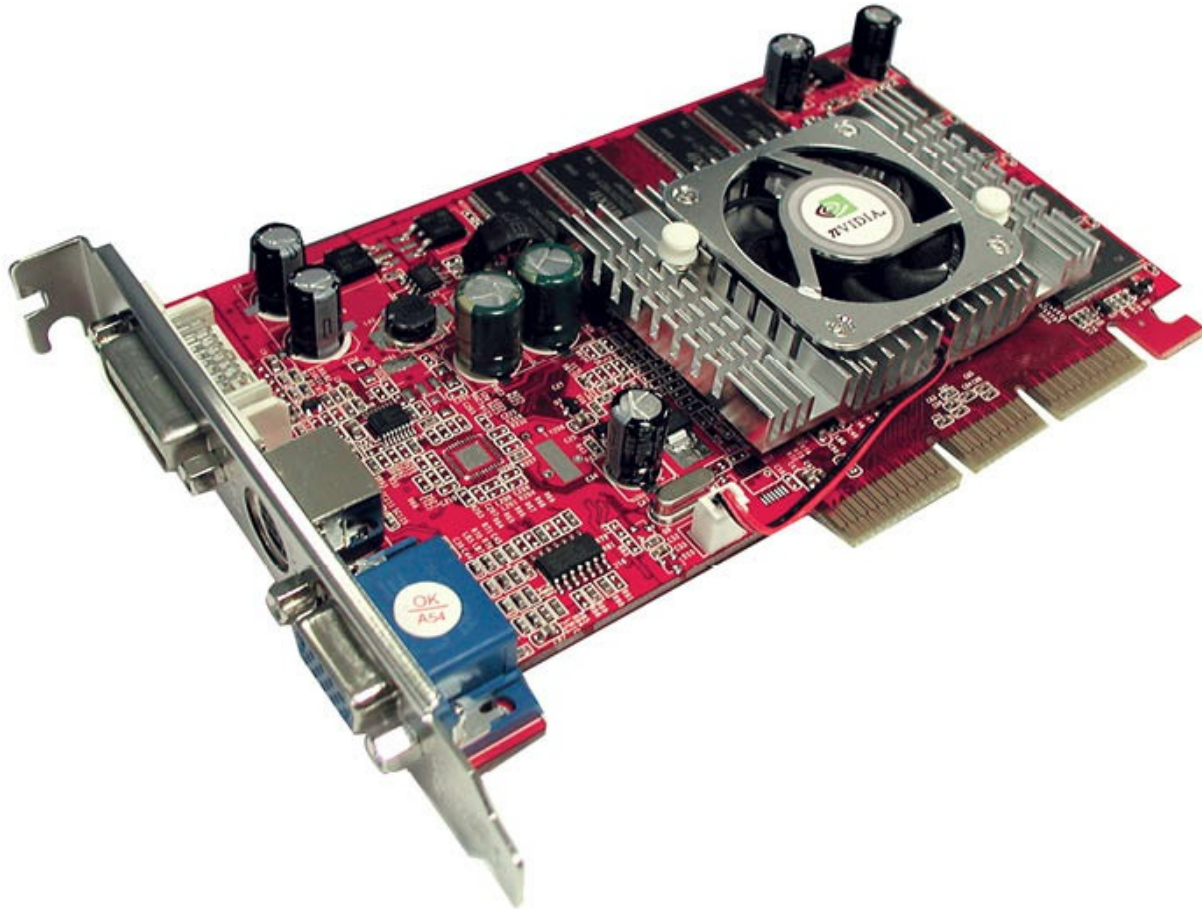

Most video cards offer various functions such as accelerated rendering of 3D scenes and 2D graphics, MPEG-2/MPEG-4 decoding, TV output, or the ability to connect multiple monitors.

Most modern motherboards have video cards integrated into them, eliminating the need for a plug-in card. However, integrated video cards are not usually as high quality as plug in cards. This makes plug in cards more suited to high end video production, graphics processing and video games.

Some plug in video cards have more specialist connections such as HDMI, DVI, S-Video or Composite for connecting to high end televisions, projectors and monitors.

# Expansion Slots

Video cards and sound cards plug into expansion slots on your motherboard.

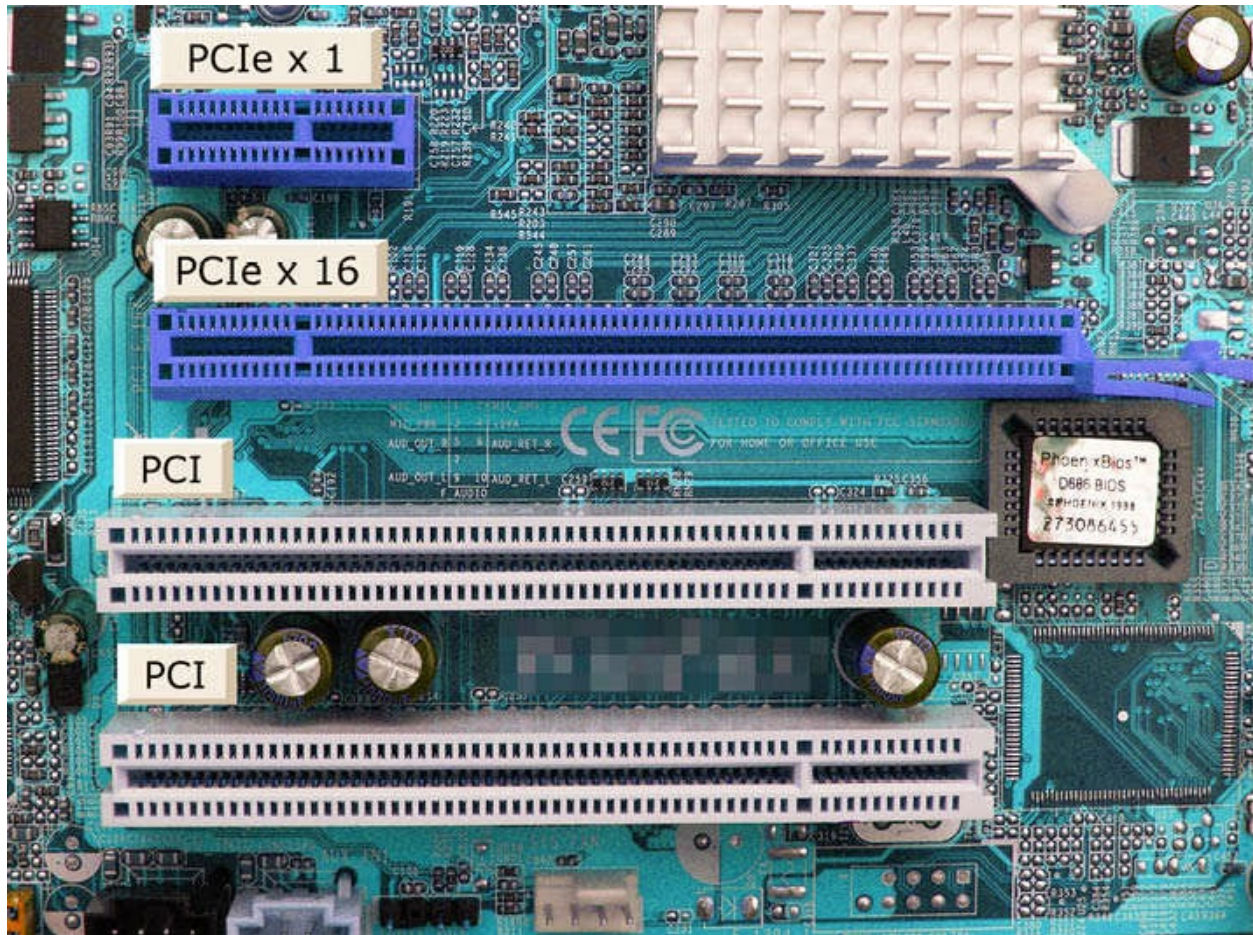

The 'PCIe x 16' slots are extremely fast and are for high end graphics cards like the one shown opposite.

The PCI slots are for sound cards and other types of cards.

The 'PCIe x 1' slots are for smaller devices such as ethernet and wifi network controllers or modems etc.

# Inside the Case

All these components connect to a large circuit board called a motherboard and is the main circuit board found in desktop and laptop computer systems. It holds many of the crucial components, such as the processor (or CPU) and memory (or RAM), and provides connectors for other peripherals.

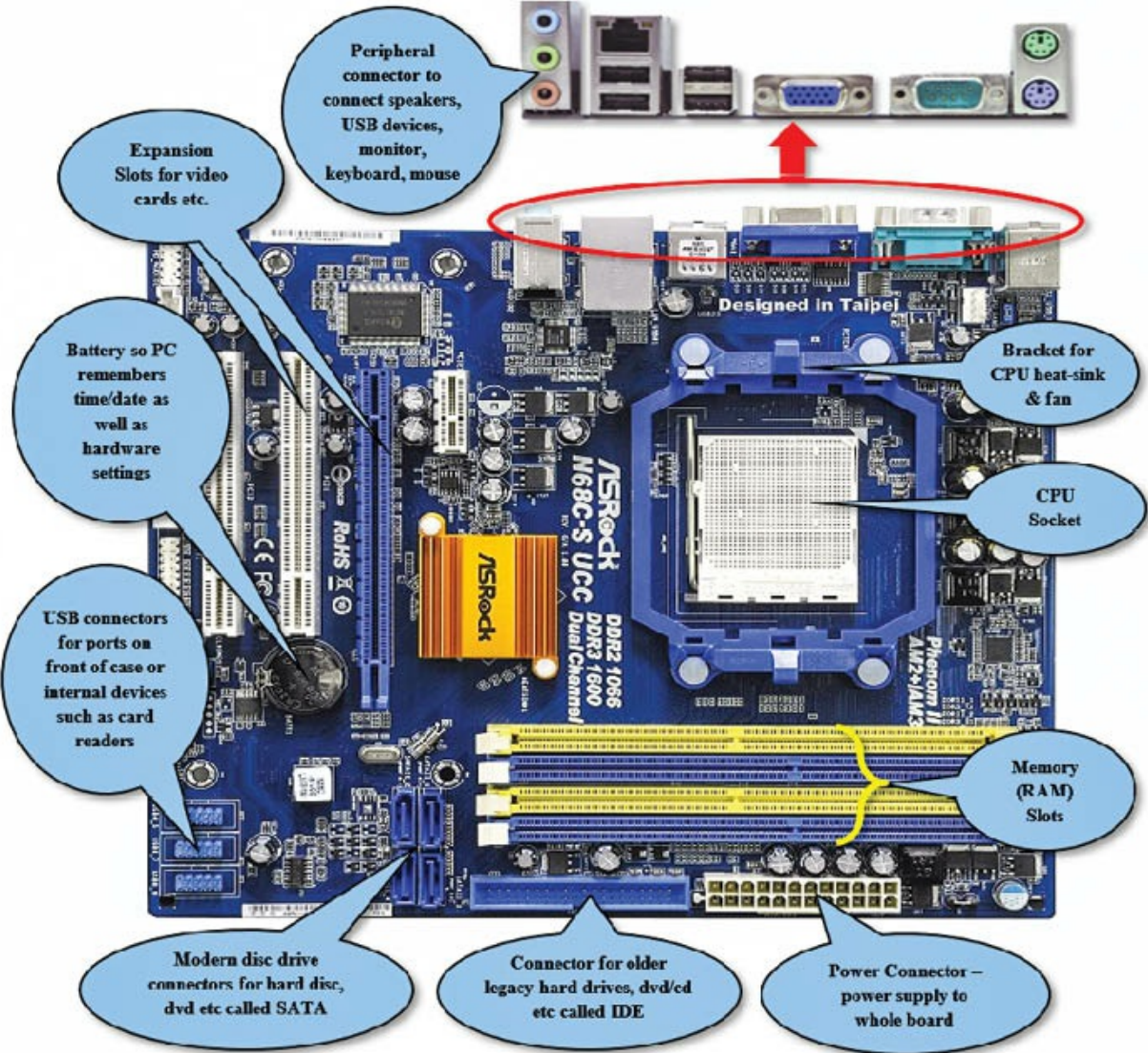

A typical desktop computer has its processor (CPU), main memory (RAM), and other essential components connected to the motherboard. Other components such as storage (hard disc, dvd drive) can be connected to the drive connectors on the motherboard using cables, as can be seen in the photograph opposite.

Cards for video display and sound may be attached to the motherboard, and plug into the expansion slots. In modern computers it is increasingly common to integrate some of these devices into the motherboard itself namely video and sound cards.



**RAM / Memory**  
Computer memory is made up of silicon chips and is the computer's working area. This is where software instructions and data are stored while the computer is turned on. Data held in RAM is lost when you turn off your PC



**CD /DVD/BluRay Drive**  
This drive allows you to play CDs, watch DVDs or Blu-Ray movies that come on a disk.



**PSU / Power Supply**  
Supplies computer with correct power and voltage from household electricity



**Hard Drive**  
Also called a hard disk, is like a filing cabinet that stores all your documents, photographs, music, your operating system (eg windows) and your installed software (eg Microsoft word)



**Processor**  
Deals with all the instructions and things you do on the PC. The processor is under a cooling fan called a heat sink, prevents processor from overheating as it generates a lot of heat



**Video/Graphics Card**  
Processes and generates the information and graphics displayed on your monitor

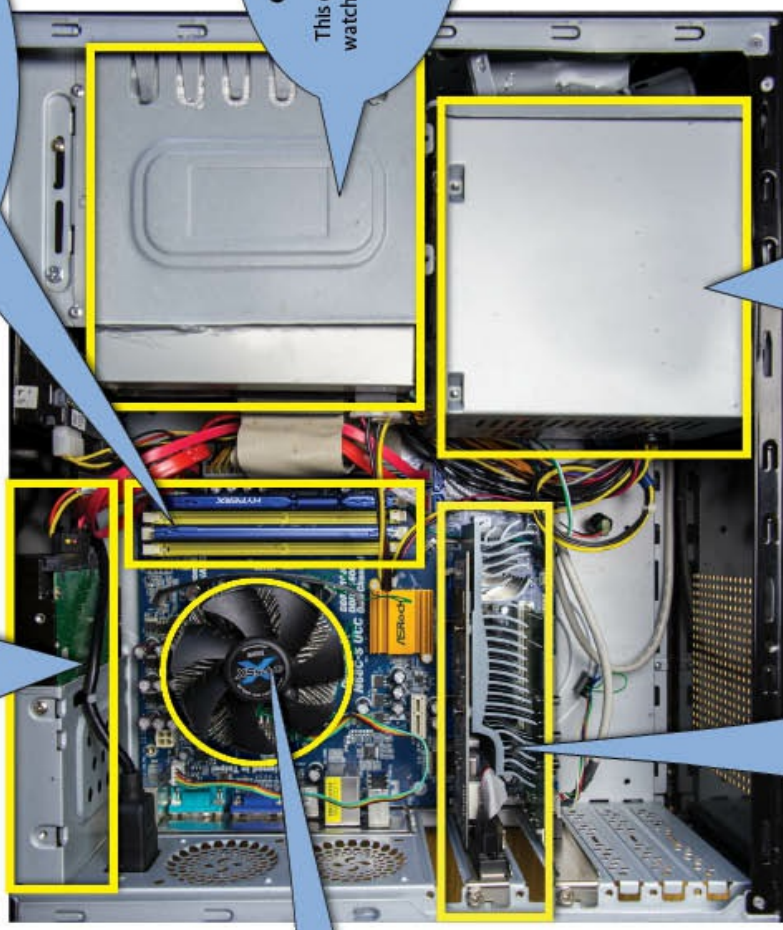

# Computer Peripherals

Computer peripherals are essentially anything that connects to the computer.

This can be input devices such as keyboards, mice and scanners; output devices such as monitors and printers; or storage devices such as hard disks, DVD and flash drives.

All these components connect to the computer using a variety of different connectors and cables; whether it's USB to connect a printer or HDMI to connect a computer screen or projector.

Lets start by taking a look at the most common of all peripherals, the printer.

# Inkjet Printer

These printers are good for the average user who just wants to print some letters or other documents and the odd few photographs. They are generally slower printers and are not suitable for printing documents with a large number of pages.

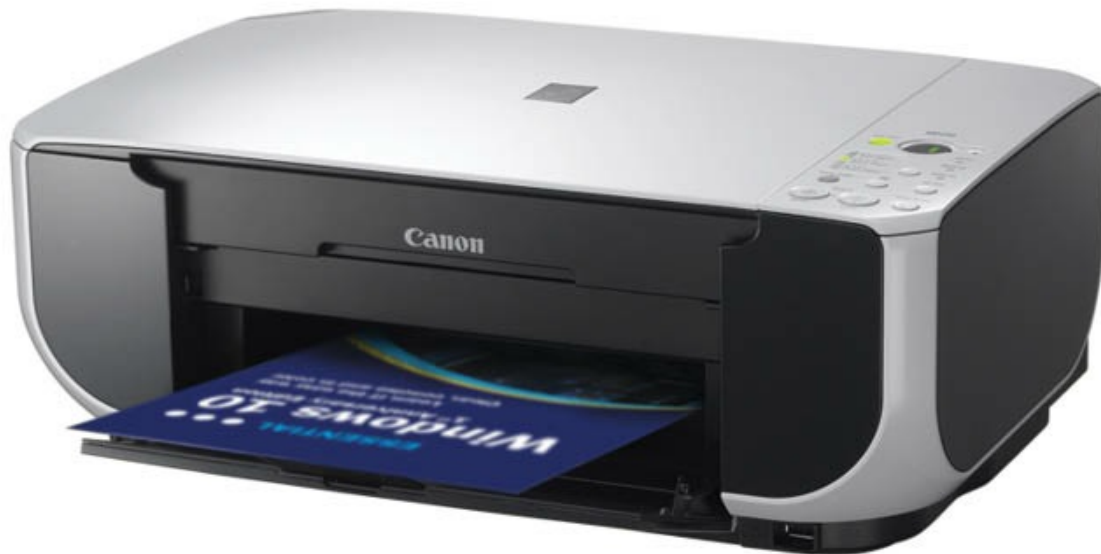

These printers can also print on labels, envelopes and specialist presentation paper (good for greetings cards if you want to print your own).

The only issue I find with inkjet printers is the ink tends to dry up if you don't print out regularly. So make sure you print out something at least once a week to keep the ink from drying up.



Inkjets work by forcing tiny droplets of ink in a pattern to form an image.



# Laser Printer

Laser printers can produce very high quality prints very quickly and are suited to high volumes of printouts and can be a bit more expensive than inkjets.

These printers are good if you do a lot of printing, for example, if you run a business or have a family that all want to print out from their own computers/laptops at the same time.



These printers come in black and white and colour and work by burning ink (called toner) onto the page; these toner cartridges can be expensive but last a lot longer than ink jet cartridges.



Laser printers use a laser beam to create the image to be printed on an electrically charged rotating drum.

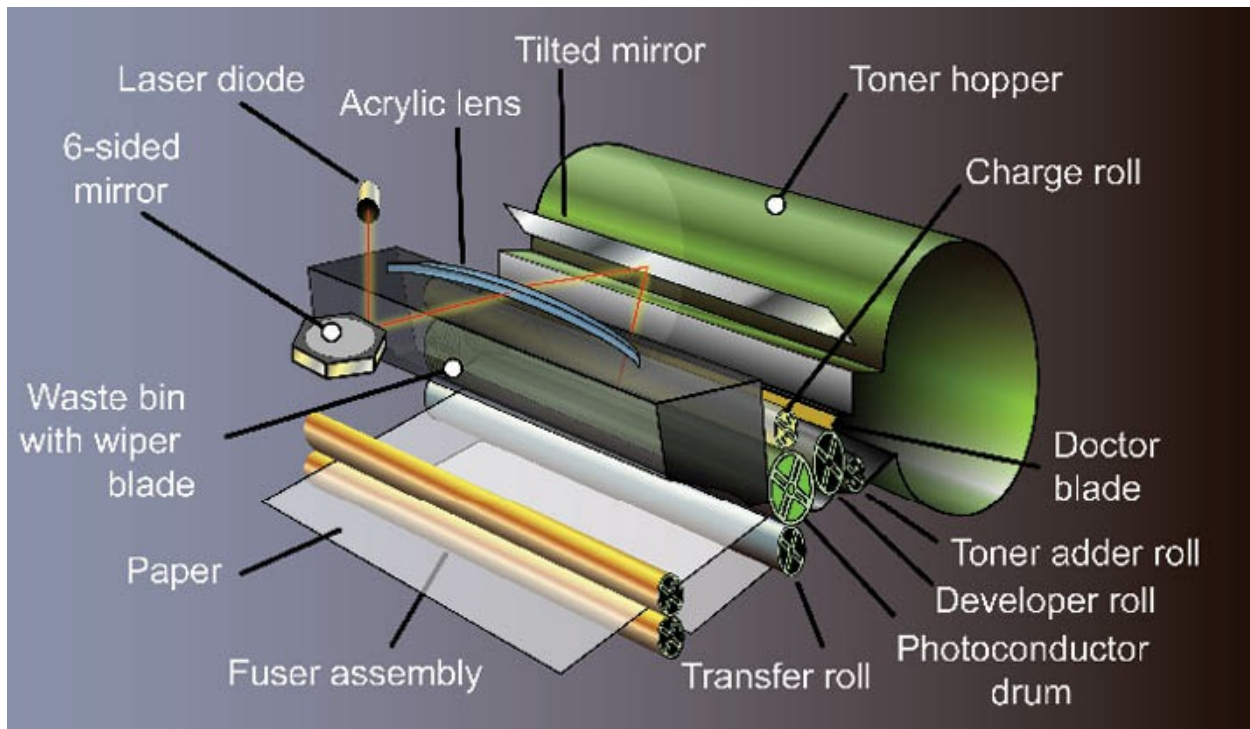

Toner particles are then electro-statically picked up by the areas on the drum which have not been exposed to the laser, creating a very sharp image.

The drum then transfers this image onto the paper by direct contact as the paper passes over it.

Finally this image is fused to the paper by the fuser unit which heats the paper temporarily melting the toner and presses it onto the page.

# USB

USB stands for Universal Serial Bus and is a universal connection used to connect all different types of peripherals to your computer as easy as possible using the same connection type.

USB 3.0, shown below left, was released on 12 November 2008, with a data rate of around 4 Gbps and is much faster than USB 2.0.

USB 2.0, shown below right, was released in April 2000, with a maximum data rate of 480 Mbps.



USB 3.0 ports are colour coded in blue, while USB 2.0 ports are colour coded in black.

The smaller USB pictured below left is called micro USB and the one next to it is called mini USB.



# Ethernet

Also known as RJ45, Ethernet is used to connect a computer or laptop to a network and to the internet.

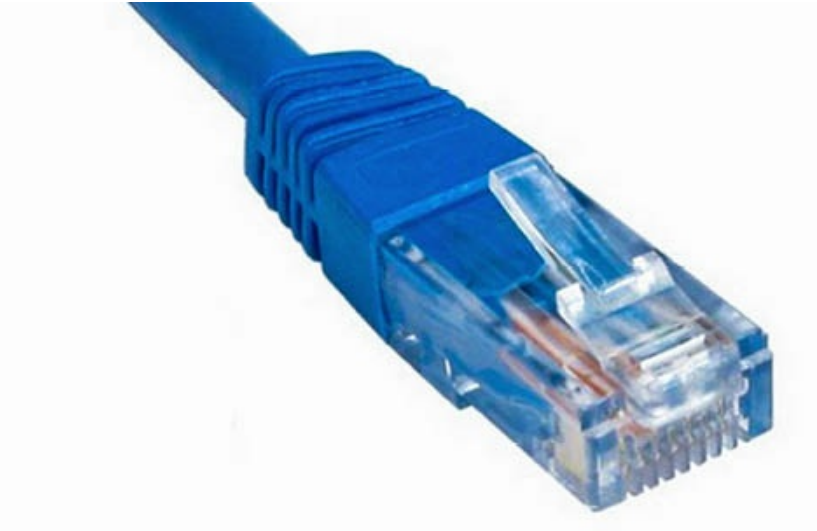

# FireWire

Also known as IEEE 1394 or iLink, this port was widely used in digital camcorders and most of them that recorded onto tape included a firewire interface .

There were two versions; Firewire 400 (on the left) and Firewire 800 (on the right).



FireWire 400 transfers data at about 400Mbps, Firewire 800 transfers data at about 800Mbps

# ThunderBolt

Thunderbolt ports are used for peripherals that require extremely fast data transfers and have been known to support speeds of up to 10Gbps.



This port is also used on Apple Mac computers as a mini display port for connecting to monitors and projectors.



# eSATA

eSATA cables connect to some types of high speed external portable hard drives. The eSATA cable cannot transmit power, unless you use eSATAp (powered eSATA).



# DVI

Digital Video Interface is a video display interface used to connect a video source (eg your computer) to a display device, such as an HD ready TV, computer monitor or projector.



DVI can get a bit confusing, as there are a number of different connectors. Here is a summary.

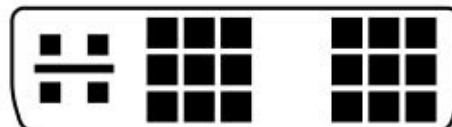

DVI-I Single Link. DVI cable with integrated analog for both analog and digital displays up to 1920 × 1200

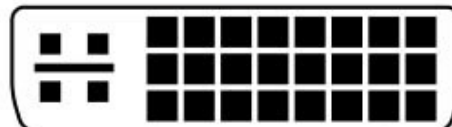

DVI-I Dual Link. DVI cable with integrated analog for both analog and digital displays up to 2560 × 1600

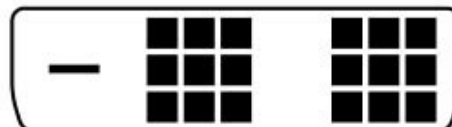

DVI-D Digital Single Link. DVI cable with digital signal only for displays up to 1920 × 1200

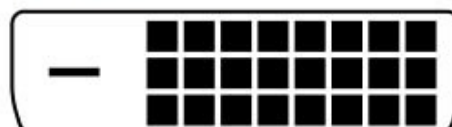

DVI-D Digital Dual Link. DVI cable with digital signal only for displays up to 2560 × 1900

# HDMI

High Definition Media Interface, is a combined audio/video interface for carrying video and audio data from a High Definition device such as a games console or computer to a high end computer monitor, video projector, or High Definition digital television.

Pictured below is Standard HDMI & Micro HDMI.



# VGA

Video Graphics Array is a 15-pin connector found on many computers and laptops and is used to connect to projectors, computer monitors and LCD television sets.



# Component Video

Carries a video signal (no audio) that has been split into three component channels. It is often used to connect high end dvd players to televisions.

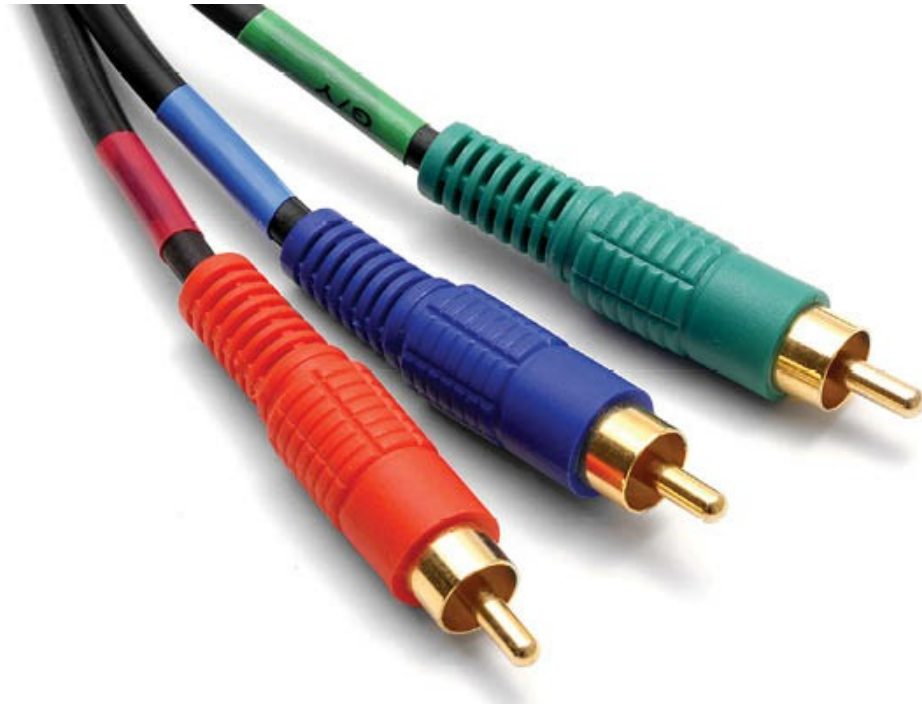

# Composite Video

Carries an analogue standard definition video signal (with no audio) used in old games consoles or analogue video cameras.



# 1/8" (3.5mm) Phono Jack

The phono jack also known as an audio jack, headphone jack or jack plug, is commonly used to connect speakers or headphones to a computer, laptop, tablet or MP3 player and carries analogue audio signals.



# **1/4" (6.35mm) Phono Jack**

These are generally used on a wide range of professional audio equipment. 6.35 mm (1/4 in) plugs are common on audio recorders, musical instruments such as guitars and amps.





## 3 Pin XLR

The XLR connector is usually found on professional audio, video, and stage lighting equipment.

Many audio mixing desks have XLR connectors to connect stage mics.



# RCA Audio

Some home audio system, televisions and DVD players use RCA cables to connect to audio receivers, amplifiers and speakers.



# **S/PDIF Optical Audio**

Also known as TosLink, these are for high end amplifiers and home cinema systems and make use of fibre optic cables to carry the audio data from a DVD player or computer system.



# **Types of Computer**

There are many different types of computer and they range from the smallest smart phone or tablet computer to large super computers that fill entire buildings.

The most common ones you'll find are micro computers, built on the micro processor.

# Desktop Computer

A microcomputer is a small, relatively inexpensive computer with a microprocessor that has become commonly known as a PC or Personal Computer. PCs now days come in various different incarnations depending on their function; desktops for power, larger hard disk, memory and larger screens or laptops and tablets for their portability.

The traditional desktop computer with a monitor, computer case, keyboard and mouse. Can either be a Mac or a PC.

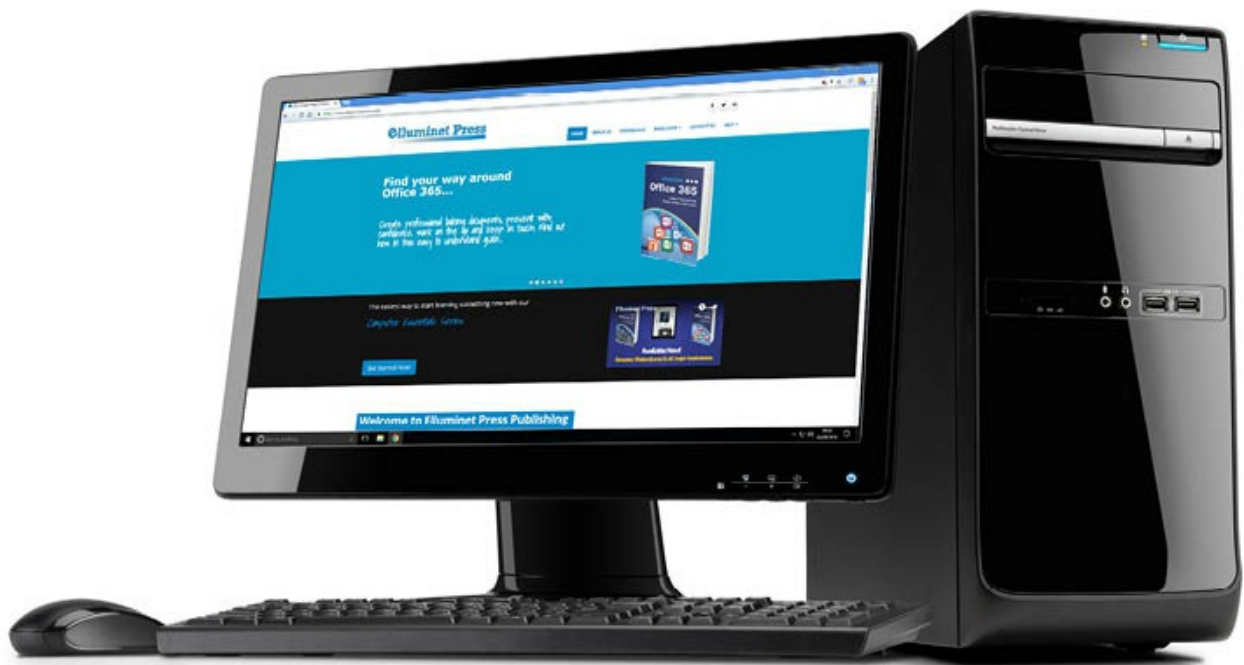

These machines are usually quite big and have the most computing power. They are aimed at gamers, graphic designers, video editors, office users and professional users. They are ideal with large screens, plenty of computing power and storage space.

Desktop computer sales for home users have been steadily declining in favour of laptops and tablet computers.

# Desktop: All-in-one

This type of desktop is virtually identical to the traditional desktop we talked about above, except the computer case has been done away with. Instead, all the internal hardware (processor, RAM, hard disk and video card) from the computer case, is integrated into the back of the screen itself.



This makes the whole system easier to set up, as all you need to do is plug in your keyboard and mouse, hook it up to the power and you're ready to go.

Some of these systems have touch screens built in, allowing you to tap icons on the screen instead of using a mouse.

Apple's iMac was the first to use this format, but many other manufacturers

have copied this design.

# Laptop

A typical laptop computer, also sometimes called a notebook. This one is a laptop running Windows 10.



Laptops usually have a similar spec to their desktop counterparts, however there are some compromises due to space. They tend to have less RAM and run slightly slower than desktops. The screens are usually between 12” and 17”.

They can run all the software and apps that are available on a desktop and come with Windows 10 or Mac OS.

The major advantage of a laptop, it its portability. The fact that you can use it in any room, sit on the sofa and surf the web, talk to your friends. Or do some college work in a coffee shop or library.



# Netbook

Netbooks are small cut down versions of laptops. They have less RAM, HDD space and are designed to be small, lightweight and inexpensive which makes them great for carrying around. The screens are usually about 10". Notice the size compared to the ball point pen in the photograph.



Netbooks can run Windows 10, some form of Linux or even Chrome OS.

These are great for working on the go or travelling around. They can run traditional software such as Microsoft Office and work well when browsing the web, social media or keeping in touch via email.

These have limited power, so anything more processor intensive such as Creative Suite or some types of games will struggle to run on these machines.

# Chrome Book

Chrome books are pretty much like netbooks and have been developed by Google to work with their cloud service.

Chrome books come with Chrome OS installed and are build around the Chrome Web Browser that allows you to run apps such as games, document writers, spreadsheets, presentations and graphics apps. Your files are stored on your personal cloud space known as Google Drive.



Chrome books require a constant internet connection in order to work and have limited memory and hard disk space, as data is intended to be stored on the cloud service.

Traditional software such as Microsoft Office, Adobe Creative Suite and many types of games do not run on these machines.

# Tablet Computers

Tend to be a cut down compact version designed with touch screens. This one is running Windows 10 in desktop mode.

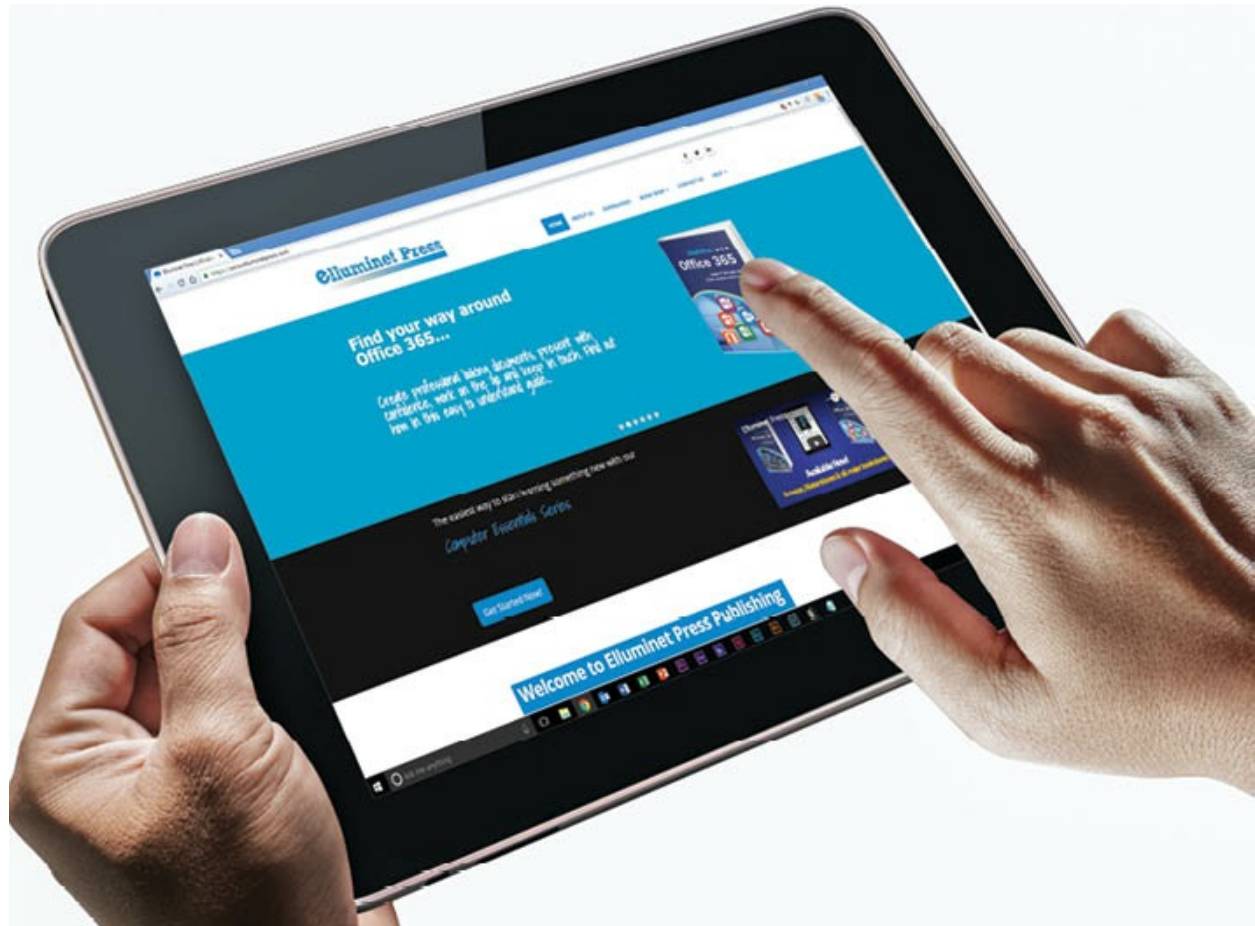

Examples of these come in the form of iPad, Microsoft Connect Tablets, Surface Tablets, Samsung Galaxy Tab, Amazon Fire and many more.

These are ideal for travelling and carrying about as they are light weight and can be stored in your bag easily.

They have countless apps available from the app store that you can download directly onto your tablet. These range from games to cut down versions of Microsoft Office and basic graphics packages. They are also good for browsing the web, social media, making video calls and keeping in touch using email.

Some tablets can even run traditional software, if they are running Windows

10.

# Hybrids

Hybrids are a cross between laptop computers and tablets. An example of a hybrid is Microsoft's surface tablet.

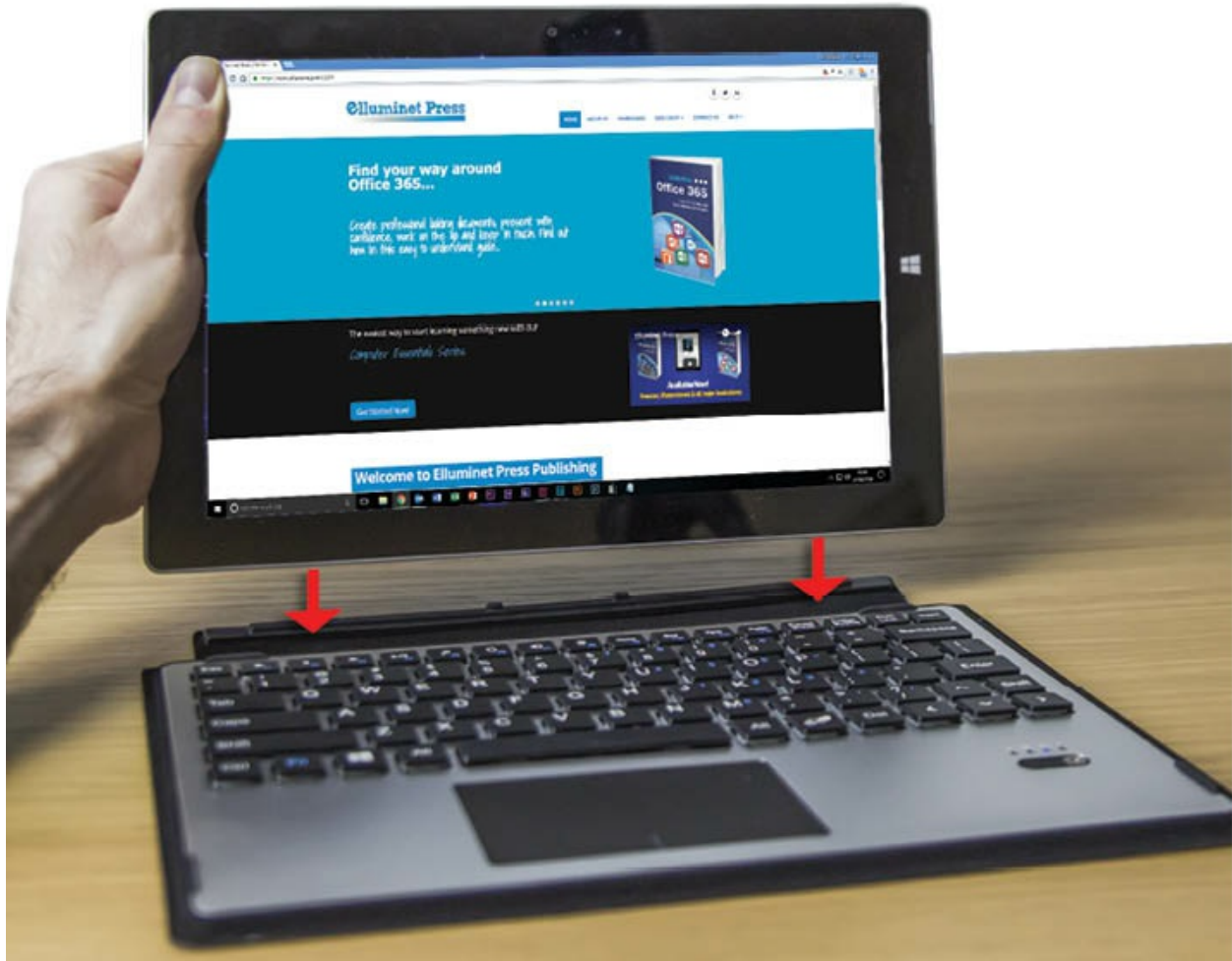

These can function as a laptop and have detachable keyboards. Once you detach the keyboard you can use the device in tablet mode, attach the keyboard and you can use it as a laptop.

These devices aren't usually as powerful as traditional laptops and are usually smaller and light weight.

They also have countless apps available from the app store that you can download directly onto your hybrid. These range from games to cut down versions of Microsoft Office and basic graphics packages. They are also good

for browsing the web, social media, making video calls and keeping in touch using email.

Some hybrids can even run traditional software, if they run Windows 10.

# Mainframe Computer

Mainframe computers operate at a very high speed and have many peripheral devices attached to them. They occupy very large space more often than not an entire room.

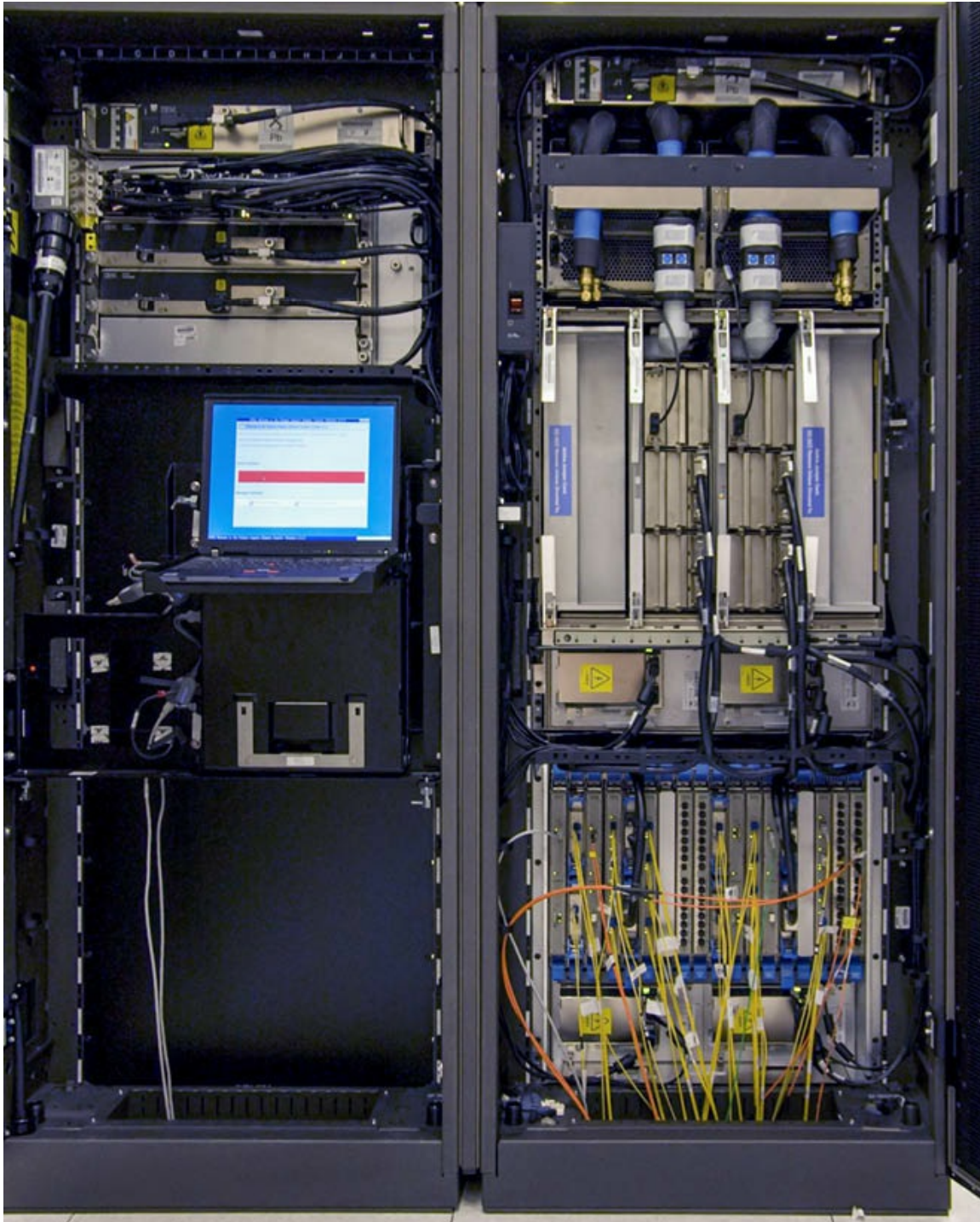

Mainframe computers have a large memory capacity and processing power and are used for critical applications such as bulk data processing of census records, statistics, and transaction processing in banks. These computers can have thousands of workstations or terminals logged in at the same time.



# Super Computer

This supercomputer shown below is Blue Gene and has over 250,000 processors and can perform an incredible 200 trillion operations per second. The entire computer is grouped into 72 cabinets, each connected by a high-speed optical network and is housed in an air conditioned room.



Supercomputers play an important role in the field of computer science, and are used for a wide range of processor intensive tasks such as quantum mechanics, weather forecasting and climate research where very large amounts of data need to be processed and calculated very quickly.

# **Understanding Hardware Specifications**

Computer specifications can often be confusing as they tend to include a lot of promotional and technical words and phrases.

In this section we'll go through the most common information you'll most likely need when shopping for a computer, laptop or tablet.

We'll take a look at some common specifications and try to decode all the technical jargon, so you can be confident when shopping around for a computer.

# So Many Machines

A lot of people ask what computer I should get. This is a valid question as there are so many to choose from. You could have a tablet, pc laptop, pc net-book, pc desktop, macbook or an imac; the list goes on.



This is what I have found from experience of using computers at different levels for different tasks.

The question I always ask myself is what I will be using the machine for.

- Will I be playing games?
- Will I be editing photos or video? Or just looking at them?
- Will I be typing documents, making spreadsheets or presentations?
- Will I be using the internet, email and a bit of video chat?
- Do I need portability?

You should take all these things into consideration when buying your machine.

For example, if you are just using your machine to type some documents, check your email and browse the internet, you perhaps don't need the most powerful machine you can find as a lot of that power is expensive and could be wasted.

On the other hand if you do a lot of video editing or photography or play the latest games you would need as much power as you can afford.

Do you want to be sitting at a desk while you use a computer? Or do you prefer sitting in your favourite chair in a coffee shop? If you prefer the coffee shop setting or moving around, perhaps consider a laptop.

# Mac or PC?

There seem to be two main types of computer available in most computer shops. One is an Apple Mac the other is a Windows PC.

One of the biggest deciding factors in buying a Mac or a PC is the price. Macs are much more expensive than PCs, in some cases costing up to twice as much as a comparable PC. This can make a Mac not worthwhile if you only need to do basic computing.

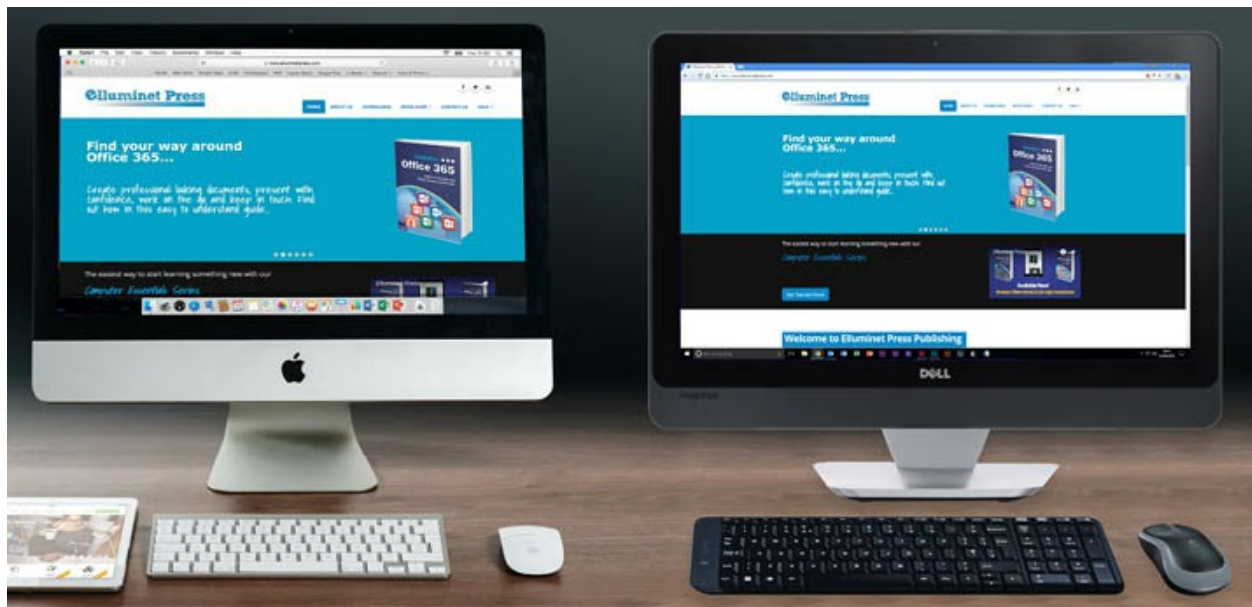

Apple is very selective about what programs and applications it allows to run on its machines so software availability can be an issue. However if the software is available for Macs, it is generally high quality and reliable, but there is less variety.

Macs tend to be a bit more secure than PCs as there are a lot more internet threats that target PCs.

Macs are used in creative industries, so a large amount of creative software is available for Mac, making them a good fit for graphic designers and people who love taking photographs, listening to music and playing movies. They have built-in software and hardware features that play music or movies, edit and store photographs and also have software for internet and email along with office applications for word processing etc.

PCs tend to be used in offices and businesses so they have a wide range of applications available for internet browsing, email and word processing.

PCs are better suited for gaming because of their powerful graphics capabilities and the wide variety of games available for PC.

PCs tend to be better for users who occasionally use their computer or use it for basic tasks such as internet, email, a few photographs, bit of music and some typing as paying the price for a Mac might not be worthwhile.

However if you use your computer a lot, love taking photographs, making videos, watching DVDs, listening to music as well as typing documents, browsing the internet and using email, a Mac might be worth its price.

# Decoding Computer Specs

In this section, we'll take a look at some common computer and peripheral specifications you might find online or when shopping for a computer.

It's worth knowing a bit about these terms before going to the computer store. I have tried to filter out most of the tech-babble and circled the information you need.

GENERAL INFORMATION	
Processor	Intel® Core™ i5-3330 processor (6 MB Cache memory, 3.00 GHz)
Operating System	Windows 8 (64-bit)
RAM	8 GB (2 x 4GB) - DDR3 - 1333 MHz - 16 GB (8 GB + 8 GB) maximum expandable memory
Graphics card	AMD HD6670 [R6670-MD2GD3] - 2GB DDR3 dedicated memory - 800 MHz core clock speed
Hard drive	2 TB - Variable rpm - SATA
Optical disk drive	Multi DVD-RW Read speed: 16x DVD, 48x CDR, 24x RW Write speed: 24x DVD -/+R, 8x DL-/+R, 8x +RW, 6x -RW, 12x -RAM
Memory card reader	Yes
USB	8 x USB 2.0
Modem/Ethernet	Realtek 8111E 10/100/1000 Mbps Ethernet
WiFi	Ralink 802.11 bgn USB Dongle 150Mbps
Video interface	Graphics Card Outputs: HDMI VGA D-Sub
Audio interface	Rear 3x 3.5mm jacks Front 1x 3.5mm Mic 1x 3.5mm headphones
Expansion card slot	1x PCIe Gen3 x16 slot 1x PCIe Gen2 x1 slot
Keyboard & Mouse	Wireless

Also called CPU. Speed measured in GHz. The higher the GHz, the more power.

I would go for Windows 10 Home (pro if you want to connect to your work network).

Normal desktop operations (word processing, email, etc.) don't require much graphics power but gaming, HD video editing, audio/music production requires much more. Consider plugin video card.

RAM or memory, is important for system performance and helps when operating demanding software. The more the better. 8GB as a minimum.

Optical discs, CDs, DVDs, and Blu-ray. Useful for playing video and films, backing up files, and essential for installing some software. Some software sold on DVD.

Hard drive is where all your files and programs are stored. Higher the number more you can store. 500GB is a minimum

Ethernet is useful if you plug into a cable modem or your work's network

USB definitely needed to plug in your cameras, printers, scanners, mice, keyboards etc. Make sure you have a couple on the front and some on rear of the machine

A necessity now days, allows you to connect to your home/work WiFi internet.

Where your monitor plugs into. Check interface matches your monitor if getting separately from PC; VGA, DVI, HDMI etc.

Where your speakers plug into. Useful to have front and rear jacks

Plug in video or sound cards slot into these inside the case

# Printer Specs

Here is a common specification you might find when shopping for a printer.

GENERAL	
Type	Printer; scanner; copier; fax
Principal Technology	HP Thermal Inkjet
PRINTER	
Printing Mode	4-color inkjet - cyan, magenta, yellow and black
Printing Resolution	Up to 4800 x 1200 dpi
Paper	Paper (plain, inkjet photo), envelopes, labels, cards, transparencies
Formats	A3+ (329 x 483 mm), A3 (297 x 420 mm), A4 (210 x 297 mm), A5 (148 x 210 mm), A6 (105 x 148 mm), B4 (250 x 353 mm), B5 (176 x 250 mm), B7 (98 x 125 mm), 100 x 150 mm, 130 x 180 mm
Speed (ppm or sec)	Black: up to 33 ppm Colour: up to 32 ppm
Compatible Cartridges	HP 920
DIRECT PRINTING	
Memory Card Slot	Yes
Compatible Cards	Secure Digital (SD), Secure Digital High Capacity (SDHC), Secure MultiMediaCard (MMC), Secure MultiMediaCard (S-MMC), Reduced-Size MultiMediaCard (RS-MMC), MMC/mobile (adapter not included, purchase separately), MMC/microSD/microSD (adapter not included, purchase separately), iD -Picture Card, Memory Stick, Memory Stick Duo, Memory Stick PRO, Memory Stick PRO Duo
OTHER	
Computer Interface	WiFi 802.11b/g/n
Platform Compatibility	Microsoft® Windows® 7 ready. For more information go to <a href="http://www.hp.com/go/windows7">http://www.hp.com/go/windows7</a> , Windows Vista® (32 and 64 bit), Windows® XP Professional (SP1) and Windows® XP Home (SP1) (32 and 64 bit), Windows® XP Home, Windows® 2000 (SP4), Windows® Foundation Server 2008, Windows® Small Business Server 2008 Standard Edition, Mac OS 10.5 or above, Linux (see <a href="http://www.hp.com">http://www.hp.com</a> )
Supplied Software	Yes
Supplied Accessories	HP 920 Black Officejet Ink Cartridge, HP 920 Introductory Ink Cartridges (Cyan, Magenta, Yellow), HP 920 Officejet Print and Scan software and user's guide on CD-ROM, ArcSoft® Scan-n-Stitch™ Deluxe, online started guide: setup.noster

Sizes of paper the printer can print on. Make sure it's at least A4. If you print photos make sure it takes size of photos you want, eg postcard size is 100mm x 150mm

How fast the printer can print out your documents. The higher the number the faster. This printer is quite fast.

These are useful if you take photos with a digital camera. This allows you to insert the memory card from the camera directly into the printer to print photos without going through the PC

Type of ink needed. This is a colour inkjet printer with 1 cartridge per primary colour

Quality of the printouts. Generally, the higher the numbers the better the quality of prints. Get the highest you can afford if you print photos

Ink cartridge code. You will need this when you buy replacement ink

Make sure this matches the version of Windows you have on your PC. Most will be windows 7 and windows 8. Check on your PC before buying.

Make sure the setup printer software is included. This is usually on a CD. This will make it easier to install your printer on your PC

If connecting to your computer using USB, make sure you buy a USB cable, some printers don't include one.





# The Internet

You can connect to the internet in a variety of different ways. Many of today's Internet Service Providers offer a DSL, Cable or Fibre Optic connection to the internet, depending on where you are.

In this section, we'll take a look at some of the most common methods and their basic setups.

We'll also take a look at some of the WiFi options and some basic security protocols.

Lastly a look at some common router specifications to help you decide on which one you need to buy, if you're out shopping for one.

# DSL

Stands for Digital Subscriber Line and is basically implemented as a DSL, meaning the download speed is faster than the upload speed. This type of internet connection connects via your telephone line, allowing you to use both your phone and internet at the same time using a DSL filter.



You'll need an a DSL / a DSL2 modem router that plugs into your phone line. These are usually supplied by your ISP, so check with them before buying.

# Fibre Optic

In some countries, the fibre optic cable runs from the exchange to the telephone cabinet in your street and uses v DSL over the copper phone line to run the last 100-300m or so to your house.



This is called FTTC or 'fibre to the cabinet' and has a very similar setup to the illustration above.

For this option to work you will need a modem router that is compatible with v DSL/ v DSL2. Check with your ISP for specific details.



If you're lucky enough to can get fibre running directly to your home, this is called FTTP or 'fibre to the premises' and is set up as shown below. This means the fibre optic cable runs from the exchange all the way to your house.



A modem supplied by your ISP connects to a fibre optic cable coming into your house.

You can then buy a cable router that has WiFi capabilities and plug that in using an ethernet cable. This will allow you to have WiFi in your house. Some ISPs will already have this built into their modem, so check with them first.

# Cable

Cable Internet is distributed via your cable TV provider and usually runs down a COAX cable rather than a phone cable.

Setups may vary slightly from different providers, however most will be similar to the one illustrated below.

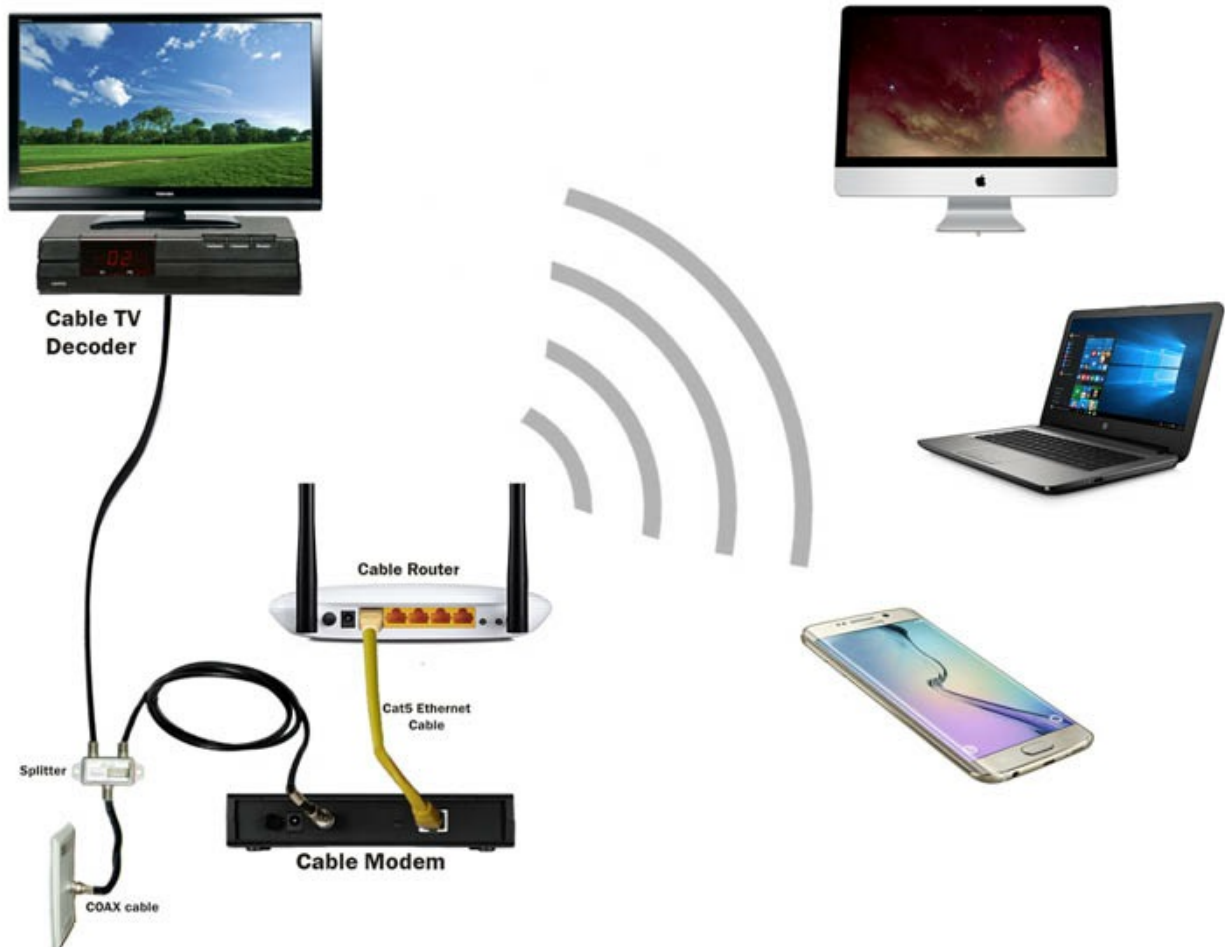

The COAX cable is split and one goes to your cable TV decoder and the other to your cable modem. From your cable modem, you can connect a cable router using an ethernet cable, which can provide WiFi. Some ISPs will already have this built into their modem, so check with them first.

# Satellite

This option is available in rural areas where line based broadband services such as DSL or Fibre aren't available.

It uses a satellite dish to provide access but speeds tend to be lower and weather conditions can interfere with reception.

## 3G/4G

This option uses the mobile/cell phone network and usually involves plugging a USB dongle with a SIM card into your computer.



3G and 4G are usually included with smart phones as part of your package or contract.

Speeds have improved over the years, however they are still very slow in comparison with DSL, Cable or Fibre Optic.



# WiFi

WiFi allows you to connect to a wireless network, also called a Wireless LAN and is usually broadcasting on a frequency of 2.4GHz and 5GHz radio bands.

Wireless LANs are usually password protected to keep them private and to prevent unwanted visitors using your WiFi. WiFi networks usually have a network name often called an SSID.

# **Dual Band or Single Band?**

Dual Band wireless LANs use both 2.4GHz and 5GHz but you'll need to make sure your devices (phone, laptop, tablet and computer) are compatible with these frequencies. Some devices only broadcast on 2.4GHz and some use both, so check the WiFi specs on your devices. There is far less interference on the 5GHz band and in some cases can provide better service.

Single Band wireless LANs use either 2.4GHz or 5GHz, not both.

# WiFi Extenders

The technical term is wireless repeater and if you live in a big house, these can help to cover your whole property if your WiFi router doesn't quite reach.

The idea is to position the extenders as far away from your wireless router as possible without losing too much of your signal quality. This will give you maximum range.



# Wireless Standards

All wireless networks are based on the IEEE 802.11 standard.

The 802.11b standard, has a maximum raw data rate of 11 Mbps using 2.4GHz and is an out dated technology now days.

The 802.11g standard, extended the throughput to up to 54 Mbps using the same 2.4 GHz band.

The 802.11n standard, also known as Wireless N, extended throughput over the two previous standards with a significant increase in the maximum data rate from 54 Mbps to 300 Mbps, and can be used on the 2.4 GHz or 5 GHz frequency bands.

The 802.11ac standard, broadcasts on the 5GHz band and has throughput of up to 1 Gbps and is sometimes referred to as Gigabit WiFi. This is accomplished by using wider RF bands for each channel.

# Wireless Security

There are currently two standards for home WiFi: WPA and WPA2, WPA2 being the more recent standard.

WPA Stands for 'WiFi Protected Access' and is implemented using a preshared key ( PSK). It is commonly referred to as WPA Personal, and uses the Temporal Key Integrity Protocol ( TKIP) for encryption.

WPA2 uses Advanced Encryption Standard (AES) for encryption. The security provided by AES is much more secure than TKIP, so make sure your WiFi router has WPA2-PSK encryption.

# Understanding Router Specifications

Most routers will have a specification similar to the one below. I have tried to highlight the things to check, depending on what type of router you're looking for and what your connection type is; aDSL, Cable or Fibre.

The spec below is a router for aDSL and vDSL/'Fibre to the cabinet' services.

WIRELESS FEATURES	
Frequency	2.4-2.4835GHz
Signal Rate	11n: Up to 300Mbps(dynamic) 11g: Up to 54Mbps(dynamic) 11b: Up to 11Mbps(dynamic)
Transmit Power	CE: <20dBm FCC: <30dBm
Wireless Functions	Enable/Disable Wireless Radio, WDS Bridge, WMM, Wireless Statistics
Wireless Security	64/128/152-bit WEP / WPA / WPA2 / WPA-PSK / WPA2-PSK
Wireless Standards	IEEE 802.11n, IEEE 802.11g, IEEE 802.11b
Dimensions (W x D x H)	7.6 x 5.3 x 1.3 in.(192 x 134 x 33 mm)
HARDWARE FEATURES	
Interface	3 10/100/1000Mbps RJ45 LAN Ports 1 10/100/1000Mbps RJ45 WAN/LAN Port 1 RJ11 Port 2 USB 2.0 Port
Button	WPS Button, LED Button, Wireless On/Off Button, Power On/Off Button
External Power Supply	12V/2A
IEEE Standards	IEEE 802.3, IEEE 802.3u, 802.3ab
VDSL2 Standards	ITU-T G.993.2, Up to 30a profile (POTS) ITU-T G.993.5 (G.vector) ITU-T G.998.4 (G.INP)
ADSL Standards	Full-rate ANSI T1.413 Issue 2 ITU-T G.992.1(G.DMT) ITU-T G.992.2(G.Lite) ITU-T G.994.1 (G.hs) ITU-T G.995.1
ADSL2 Standards	ITU-T G.992.3 (G.DMT.bis) ITU-T G.992.4 (G.Lite.bis)

Broadcast frequency, make sure this matches the frequency on your laptop, tablet. 2.4GHz or 5GHz

Compatible 802.11 WiFi standards

Security encryption standards for securing your network

Required if you are connecting to ADSL line or VDSL in FTTC setup via phone line 

VDSL / VDSL2 if you are connecting to fibre as a FTTC setup via phone line.

ADSL2 if you are connecting to the internet over your phone line using ADSL service.

The spec below is a router for cable and 'fibre to the premises'

WIRELESS FEATURES	
Frequency	2.4-2.4835GHz
Signal Rate	11n: Up to 300Mbps(dynamic) 11g: Up to 54Mbps(dynamic) 11b: Up to 11Mbps(dynamic)
Wireless Security	64/128/152-bit WEP / WPA / WPA2,WPA-PSK / WPA2-PSK
HARDWARE FEATURES	
Interface	4 10/100Mbps LAN PORTS 1 10/100Mbps WAN PORT
Button	WPS/Reset Button Wi-Fi On/Off Button Power On/Off Button
Antenna	2*5dBi Fixed Omni Directional Antenna
External Power Supply	9VDC / 0.6A
Wireless Standards	IEEE 802.11n, IEEE 802.11g, IEEE 802.11b
Dimensions (W x D x H)	7.6 x 5.3 x 1.3 in.(192 x 134 x 33 mm)

Broadcast frequency, make sure this matches the frequency on your laptop, tablet. 2.4GHz or 5GHz

Compatible 802.11 WiFi standards and maximum data rates

For cable and 'fibre to the premises' modems – connects using Ethernet cable



# **Data Transfer Rates**

In communication systems, data is usually measured in bits per second, not bytes per second.

# Bytes and Bits

Computer data is measured in bytes. There are 8 bits in one byte. So to calculate the data transfer rate you need to convert the size of the data from bytes to bits. Don't get megabits confused with megabytes.

To convert bytes to bits you need to multiply by 8, so

**2 bytes is  $2 \times 8 = 16$ bits**

Going a bit further

**2 kilobytes is  $2 \times 1024 = 2048$  bytes**

*Remember there are 1024 bytes in a kilobyte*

Now convert to bits. There are 8 bits in one byte so

**$2048 \times 8 = 16,384$  bits**

*Remember, always convert down to bytes then multiply by 8.*

Another step further

**2 megabytes is  $2 \times 1024 = 2048$  kilobytes**

*There are 1024 kilobytes in a megabyte*

**$2048 \text{ kilobytes} \times 1024 = 2,097,152$  bytes**

Now multiply by 8 to convert to bits

**$2,097,152 \text{ bytes} \times 8 = 16,777,216$  bits**

Large numbers get complicated, so 16,777,216 bits can be converted to 16 megabits.

So 2 mebabytes per second would be 16 megabits per second.

A short cut would be, if you are converting megabytes to megabits, you can just multiply by 8. Same with kilobytes to kilobits, or gigabytes to gigabits. It gets a bit more involved if you are converting, for example, kilobytes to bits or megabytes to bits.

Going the other way is very similar

Say I had an internet connection of 40mbps (megabits per second)

40 megabits per second  $\div 8 = 5$  megabytes per second

So how long will it take to download?

To calculate this use **file size  $\div$  data rate = time to download**

So for example a 70megabyte file with a 40mbps (megabit per second) connection speed.

First you need to convert both data so they use the same units - you can't use both megabytes and megabits.

**40 Mbps  $\div 8 = 5$  MBps** (Mega Bytes per second)

So...

**Time to download = 70MB  $\div$  5MBps** ( Mega Bytes per second)  
**= 14 seconds**

5GB File?

**5GB x 1024 = 5120MB** (remember the units need to be the same; can't use gigabytes and megabytes)

**5120MB  $\div$  5MBps = 1024 seconds** (no one quotes that many seconds so you can divide this by 60 to get minutes)

**1024 seconds  $\div$  60 = approx 17 mins**

MBps = Mega Bytes per second

Mbps = Mega Bits per second.

So when your broadband provider boasts "40meg" it is actually 40 megabits per second, not 40 megabytes per second. A lot slower since 40Mbps = 5MBps.

# **Computer Networks**

When two or more computers are connected together they are said to be networked. A network can be two or three computers connected together in a small office or connect computers together in different parts of the country.

There are three main types of networks. LAN, MAN & WAN.

# Local Area Networks ( LANs)

A small network contained in a single site or building is called a LAN or Local Area Network.

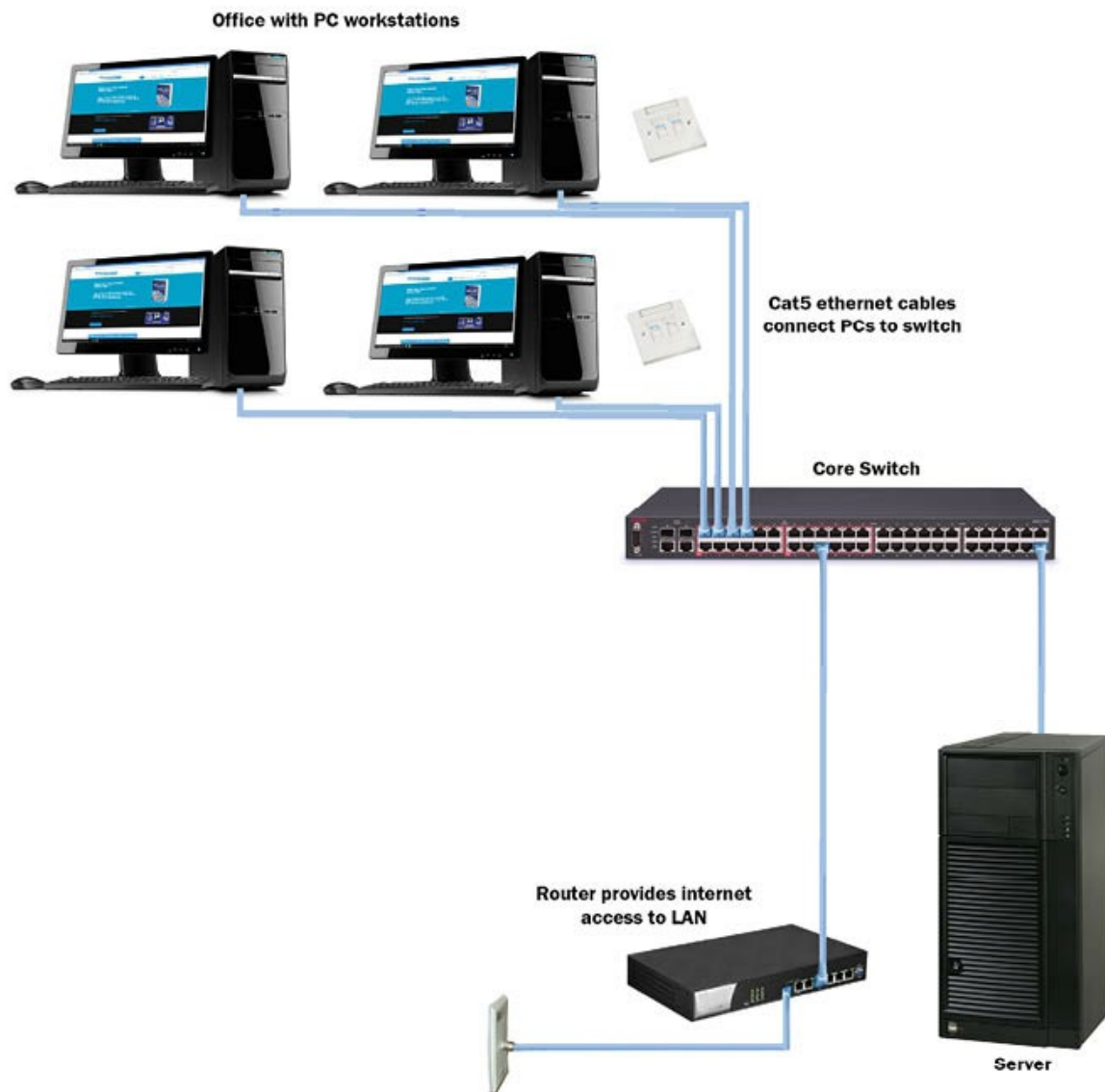

As you can see in the diagram, the network covers a small area. The computers could be split up into different offices or all in one room and can all access resources served from the file server and use internet services provided by the router.

They are all connected together using a switch.

# Metropolitan Area Networks (MANs)

A metropolitan area network is a network that connects computers in a region larger than a local area network (LAN) but smaller than a wide area network (WAN) and is usually an interconnection of networks in a city that form a single larger network.

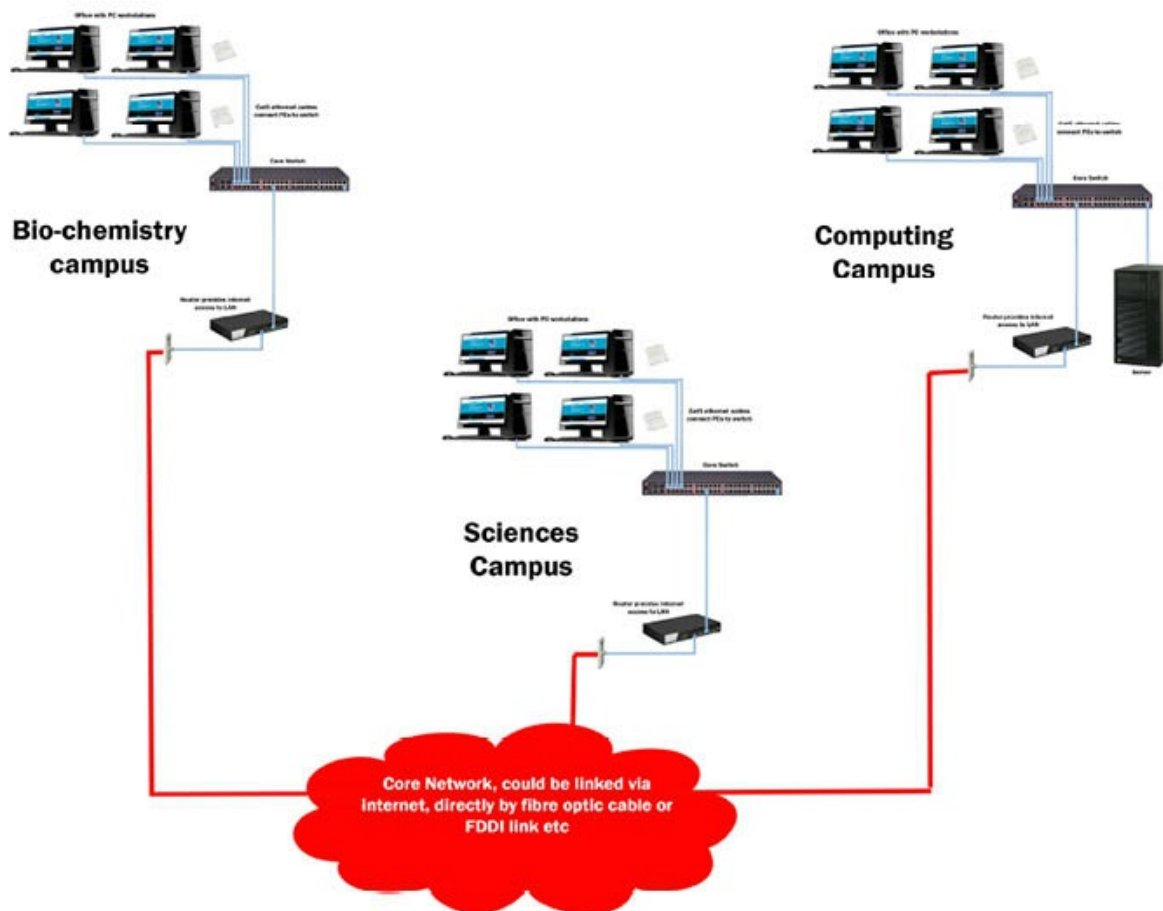

In this example, we have a university campus network with buildings spread all over the city. Each campus has its own LAN, and the LAN at each campus is linked together to form a much larger network called a MAN.

These could be linked using fibre optic cables or even a virtual private network using the internet.

# Wide Area Networks ( WANs)

A network that connects computers and LANs in different parts of the country is called a WAN or Wide Area Network.

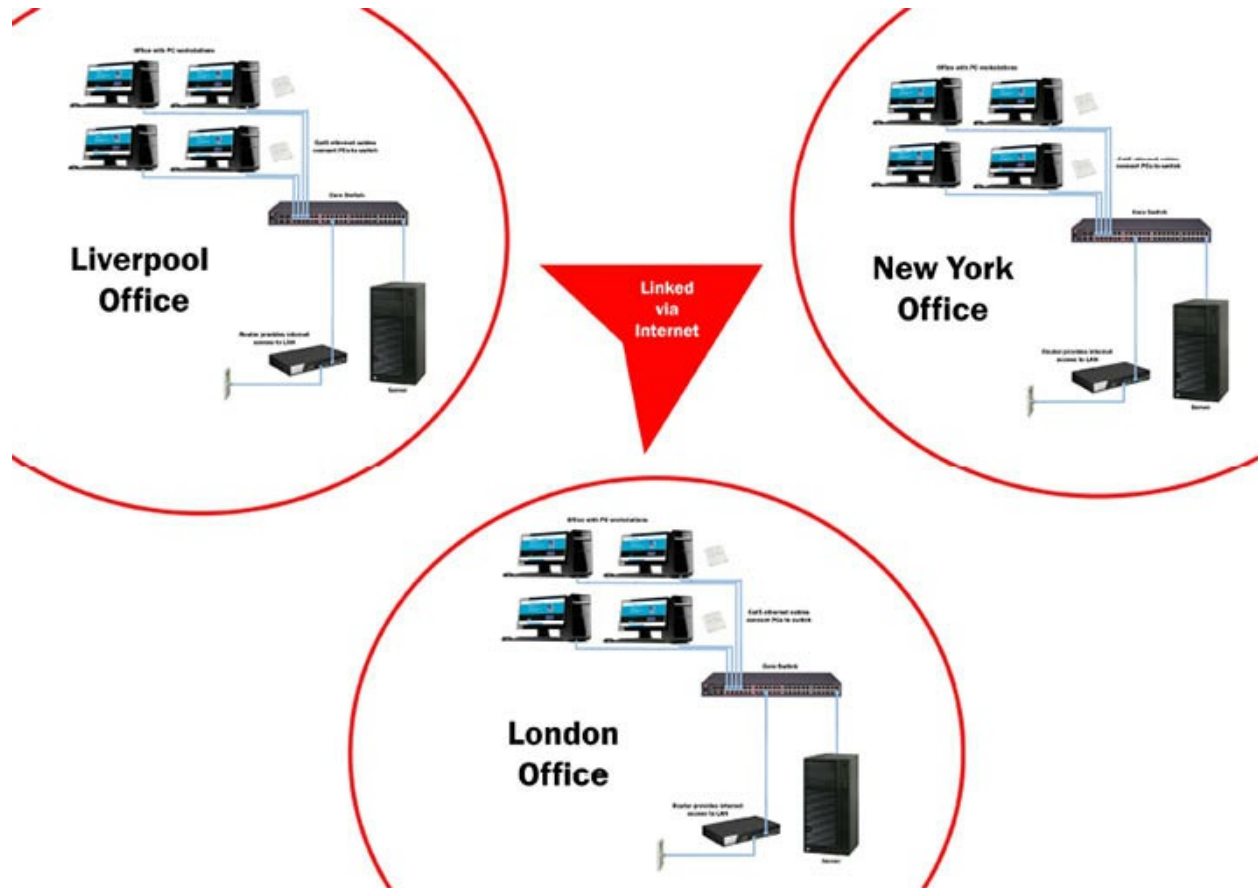

This example is of a multinational organisation that has offices in different cities and countries. Each organisation can have its own LAN and is linked to a larger network over the internet.

A WAN can also have MANs connected to it as well as lots of smaller LANs.



# Peer-to-peer Network

On peer-to-peer networks, all the computers on the network are equal in role, and are usually connected together in a small office or maybe at home.

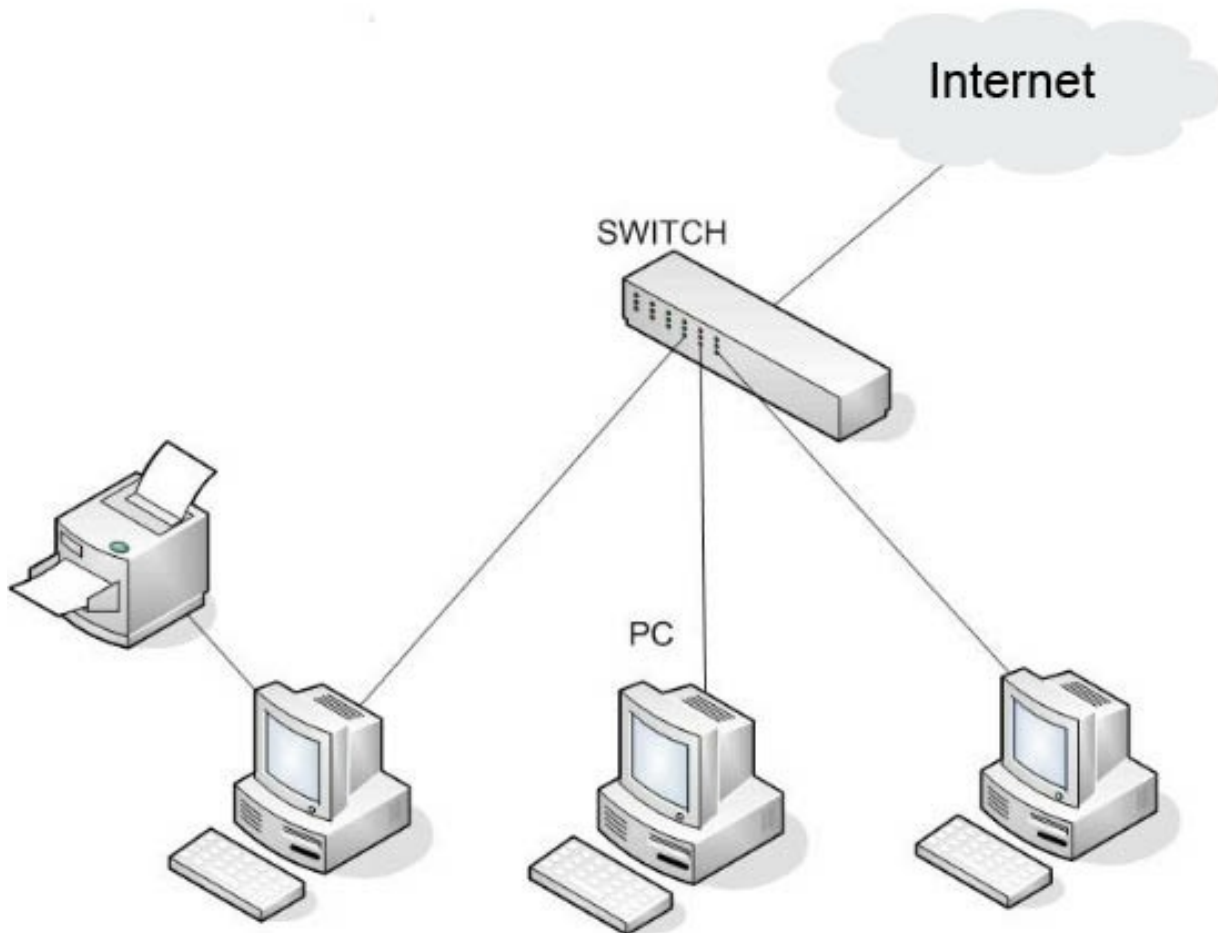

An example of a peer-to-peer network is one that might be found in a modern household, a computer in the study, one in the living room and one in the bedroom, all sharing one internet connection and one printer. Each computer, laptop, tablet or phone is called a peer.

Practically these computers are probably connected using WiFi to a switch that is built into a router provided by an ISP.

# Client-server Network

Client-server networks are found in businesses, colleges and places you would find a lot of computers.

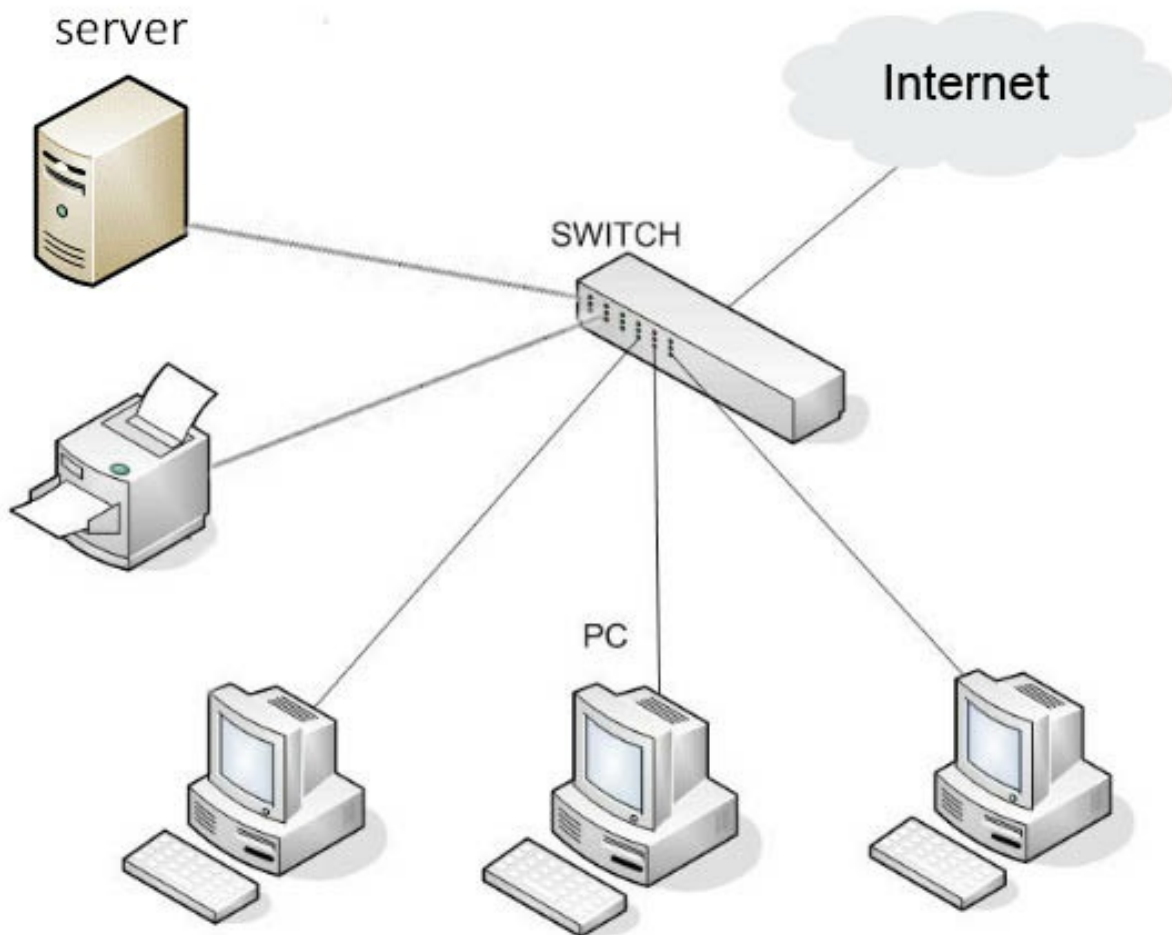

These networks consist of a number of PCs called clients located in offices on an employee's desk, in classrooms and are usually connected using CAT5 cables.

Also on the network there would be one or more servers. Servers are large computers that hold data and shared resources that are served to the client PCs on the network. Hence the name client-server.

# Ethernet

Computers are usually linked up using copper RJ45/ CAT5. This one below is called an unshielded twisted pair ( UTP).

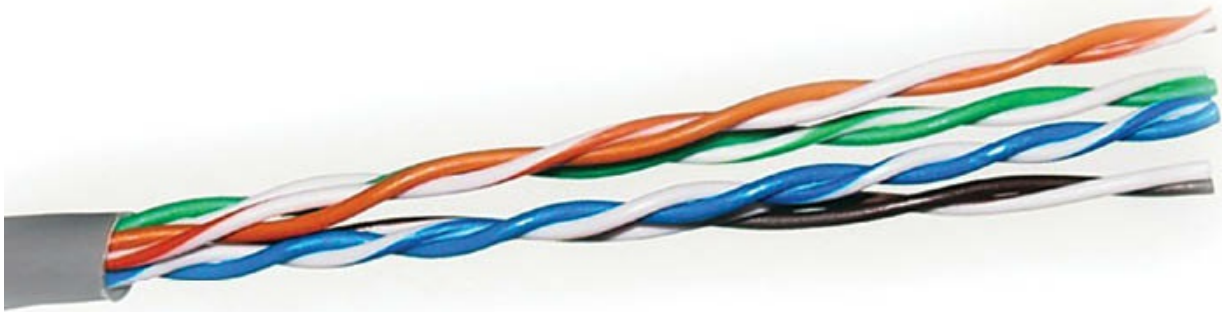

...or fibre optic cables

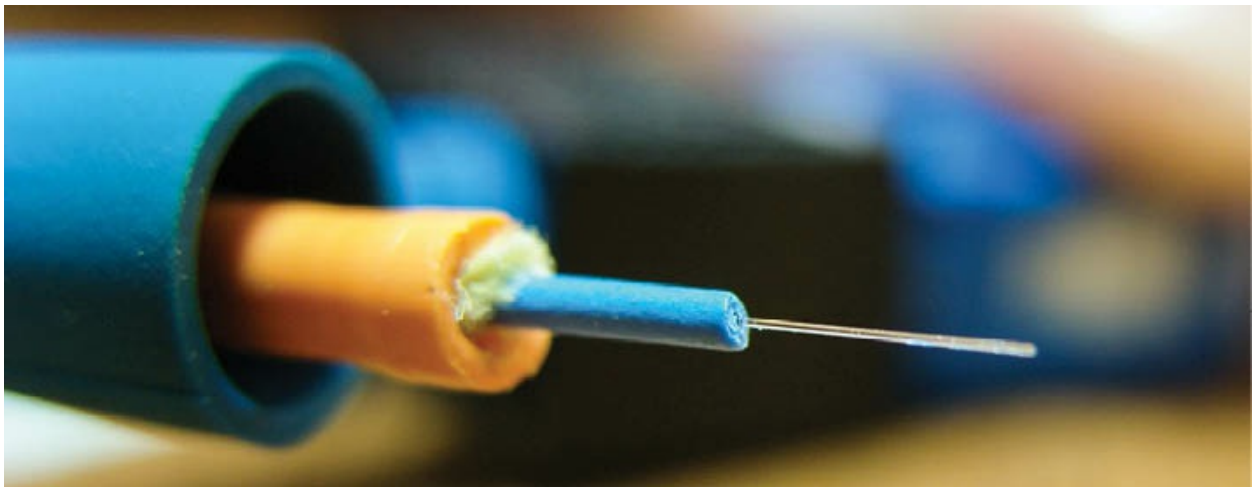

Computers are usually plugged into a device called a switch, shown below.



This device passes data between the different computers on the network.

CAT5 cables connect computers to the switch using either fast ethernet (100BaseT) or gigabit ethernet (1000BaseT), and has a limit of about 100m. The cables are terminated with a standard RJ45 connector. Note there are 4 pairs of wires (orange, green, blue, brown) and 8 pins.

The connectors are wired as shown below.

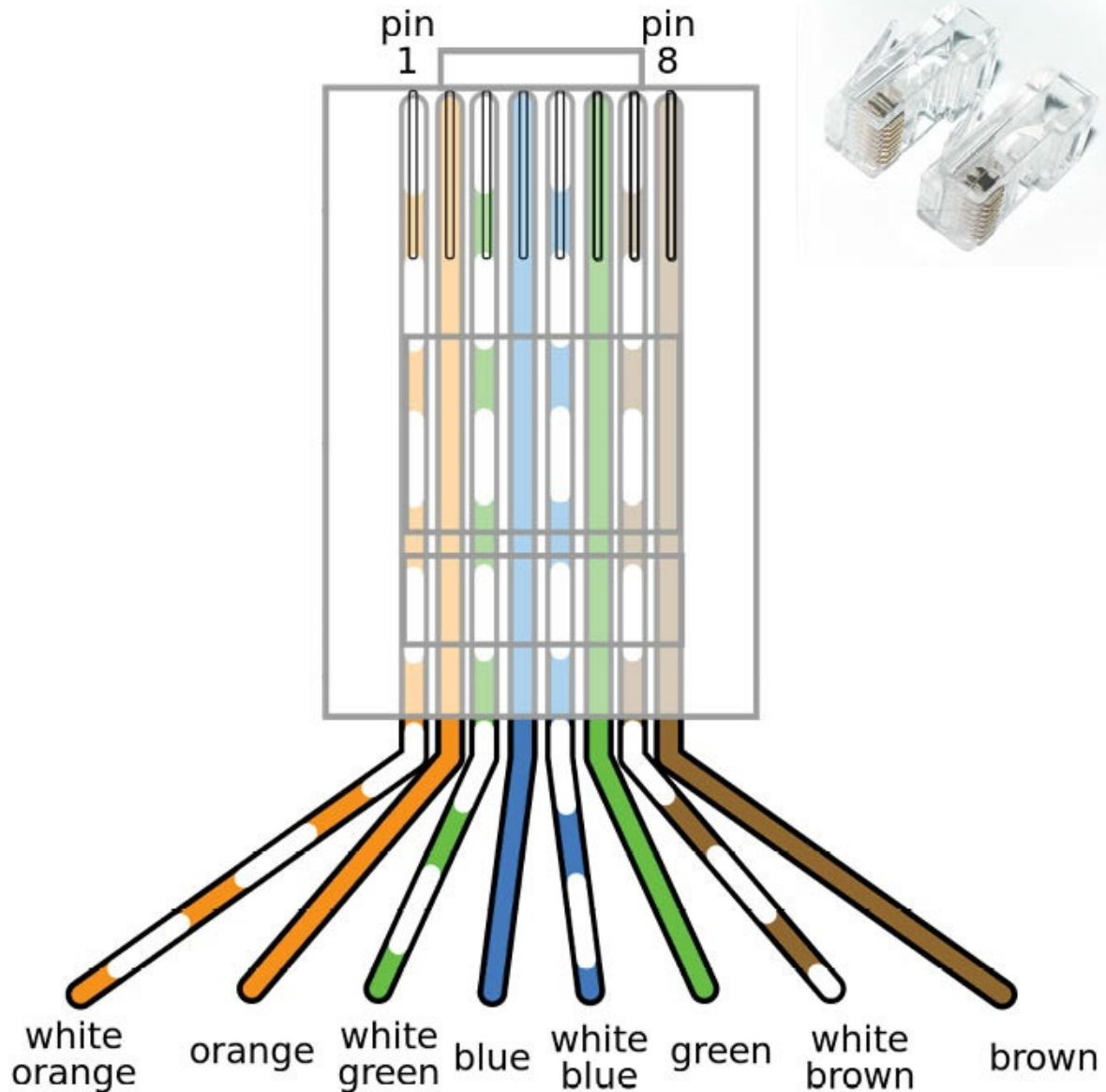

Fibre optic cables are generally used when distances are far greater and can link different sites together.

# Cellular Network

A cellular network or mobile network is a wireless network distributed over land and is divided into areas called cells. This is how a cell phone or mobile phone network operates.

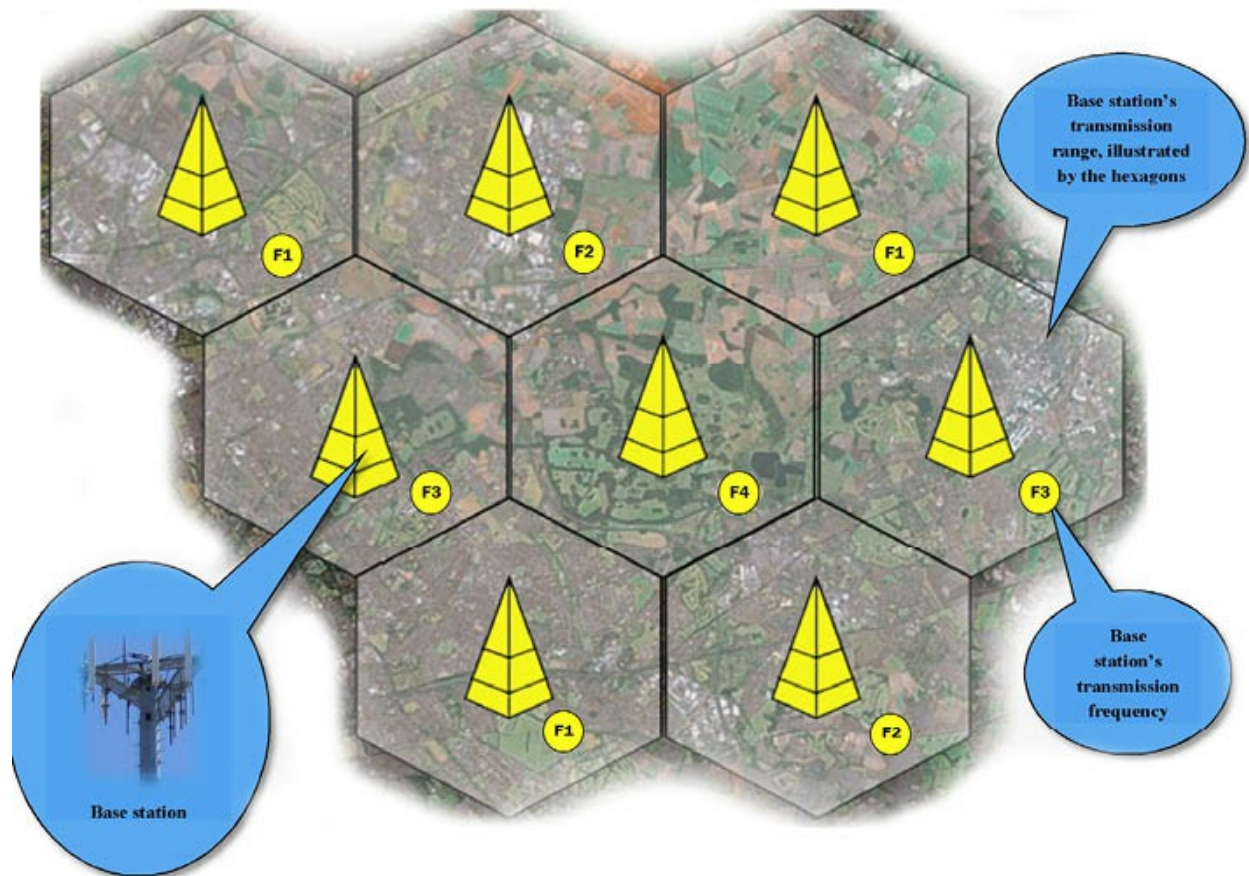

Each of these cells is assigned a frequency (eg F1-F4) each served by a radio base station. The frequencies can be reused in other cells, provided that the same frequencies are not reused in neighbouring cells as it would cause interference.

As you move through the cells with your cell phone the system automatically switches your call between the base stations, this is called roaming.

# Bluetooth

Bluetooth is a wireless technology for exchanging data over short distances using a frequency of 2.4 to 2.485 GHz. This is often referred to as a PAN (or personal areal network) and can be used to connect headphones, wireless mice, smart phones and make small data transfers.



Many smartphones now use Bluetooth to connect different accessories and can even link to your car's stereo system to make a nice hands free kit, allowing you to safely take calls while driving.

▪

# Cloud Computing and the Web

The “cloud” was originally a metaphor for the internet and many network diagrams represented the internet with a symbol of a cloud.

As internet services became more advanced, the cloud became a set of hardware devices; data servers, application servers, connected to networks with large storage space that provide services such as email, apps and disk storage for documents, music and photos.

These cloud services include the delivery of software and storage space over the Internet, based on user demand having as little as possible stored on the user’s machines.

If you have an account with a web-based e-mail service like Hotmail or Gmail, then you’ve had some experience with the cloud. Instead of running an e-mail program on your computer, you log into a web e-mail account remotely.

The storage for your account doesn’t exist on your computer, it’s on the cloud. In this example, files would be stored on OneDrive and if you’re using Google, your files would be stored on GoogleDrive.



You can run Microsoft Word online using your tablet, laptop or phone to edit your documents. If you are using GoogleDrive, you can use GoogleDocs to edit your document. All these can be used through a web browser on your device.

You can also collaborate with other users; colleagues or friends. You can share photos or documents for them to see and edit; working on projects together around the world, or just share the latest photo with a friend.

This has become a huge advantage as data can be stored centrally making backups easier. Applications and servers can be built and maintained centrally by dedicated support staff making downtime a minimum.

Cloud computing can be further broken down into different types

**Software-as-a-service or ( SaaS):** Office 365, Google Docs or web based emails are examples of this where applications are designed for end-users and



delivered over the web

**Platform-as-a-service or ( PaaS):** is the set of tools and services designed to make coding and deploying applications quick and efficient

**Infrastructure-as-a-service or ( IaaS):** 'Rackspace' web hosting provider is an example of this and provides the hardware and software that powers the cloud, such as servers, storage, networks, operating systems and so on.

# Computer Software

Computer software comes in a variety of different forms. Applications are pieces of software that can be quite large and were originally designed to run on a desktop computer; you use the application using a keyboard and mouse. Examples applications are Microsoft Office Suite 2016: Word, Excel, PowerPoint, Adobe Creative Suite: Photoshop, Adobe Premiere and so on.

A more recent incarnation of software is the App. Apps are usually smaller in size and are designed with a touch screen in mind. So for example, facebook has an app. Microsoft Office Suite also has App versions of its software to complement their desktop counterparts.

So as an example, Microsoft Word can be used as a full featured desktop application and also has an App version, that has less functionality but allows you to edit your documents on your tablet or phone using the App.

The most important piece of software is called the Operating System. This can be Windows 10, MacOS, iOS or Linux.

# The Operating System

The Operating System or OS is a piece of system software that manages all the hardware and software resources available on your computer. This could be memory allocation, storage device management, file management, as well as providing a nice user interface of windows and icons for you to interact with.

On laptops, PCs and some tablets you could have Microsoft Windows 10 as your Operating System.

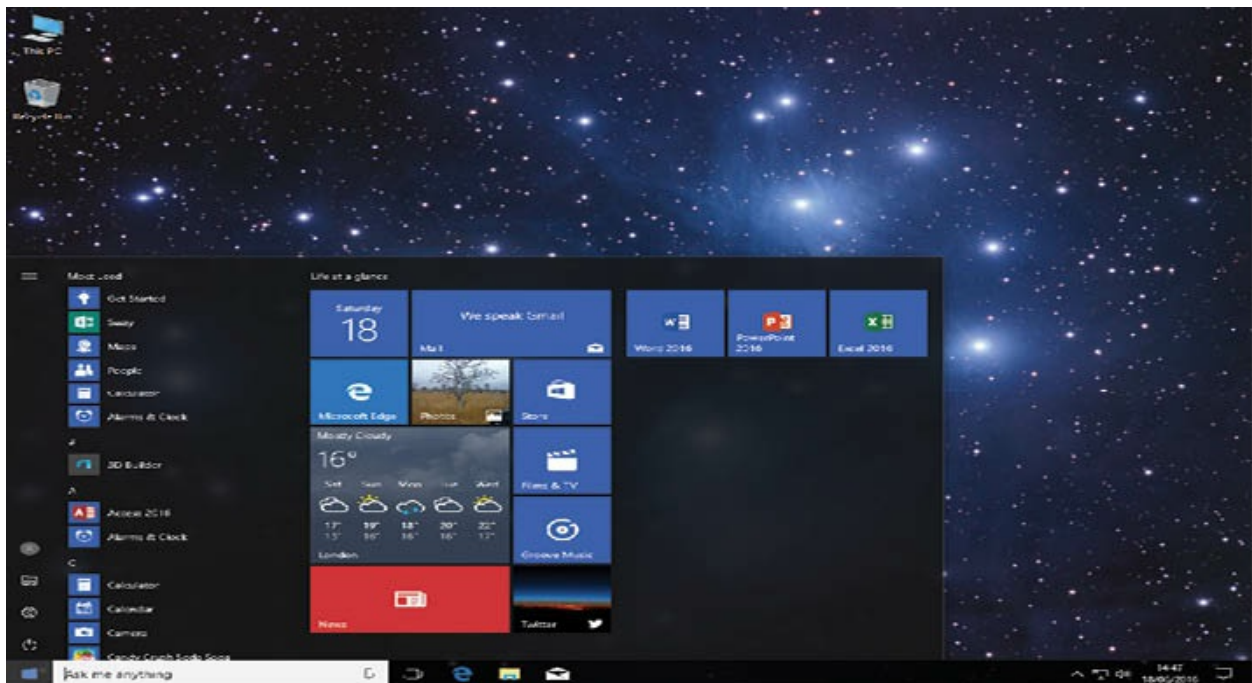

On a Mac you'd be running MacOS

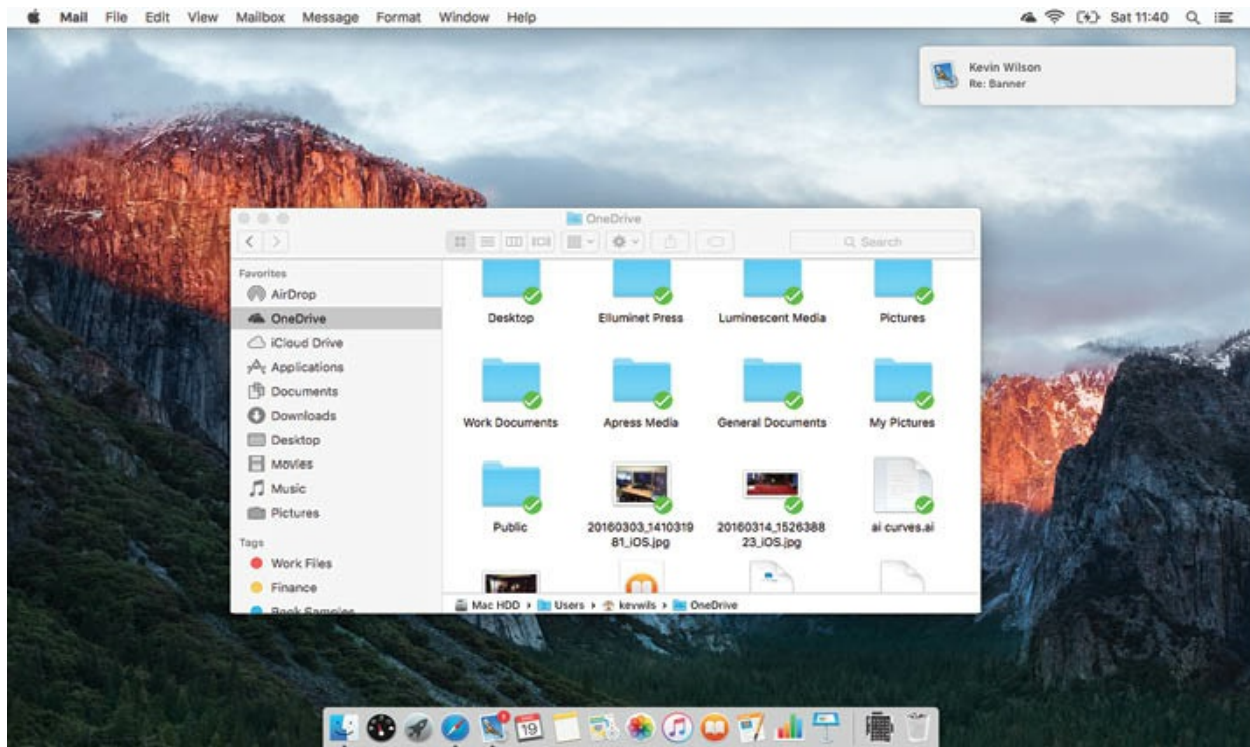

On an iPad or iPhone you'd be running iOS.



Other tablets will have their own operating system.

In each case, the system provides a Graphical User Interface (GUI) for you to work with, using menus, icons and images to represent apps and commands.

# Apps & Applications

As mentioned earlier, applications are pieces of software that can be quite large and were originally designed to run on a desktop computer; you use the application using a keyboard and mouse.

Examples applications are Microsoft Office Suite 2016: Word, Excel, PowerPoint, Adobe Creative Suite: Photoshop, Adobe Premiere and so on.

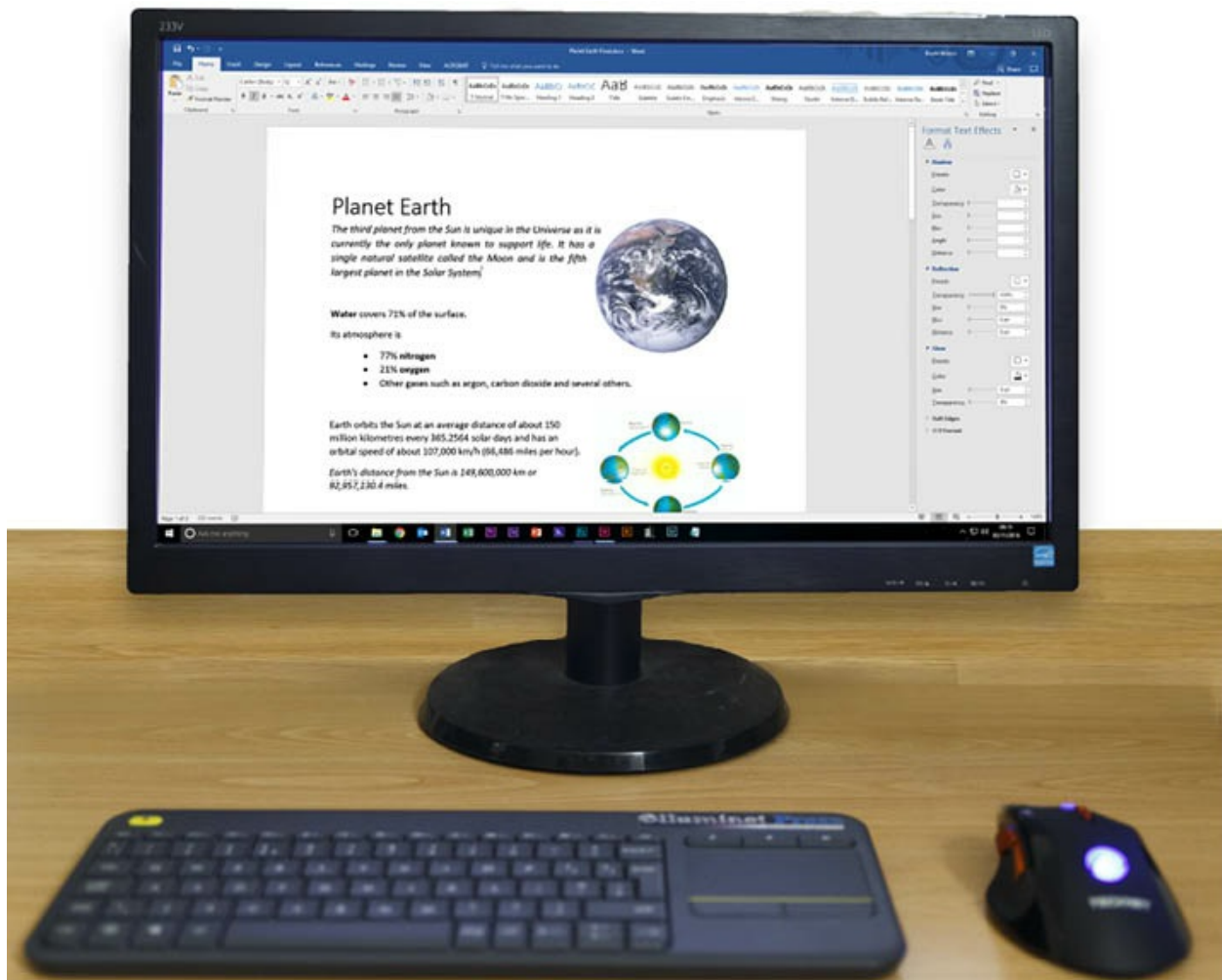

On the setup above, we have Microsoft Word running on a desktop computer. You interact with the system using a keyboard and mouse, so the application and its interface is designed with this in mind.

This is an example of a desktop application. This application could also be running on a laptop.

A more recent incarnation of software is the App. Apps are usually smaller in size and are designed with a touch screen in mind. In the demo below, we have a maps app running on a tablet.



You interact with the system using your finger to manipulate the screen directly using a number of finger gestures; point, drag, tap etc. The interface is designed with this in mind, making icons bigger to enable you to tap on them with your finger.

Microsoft Office Suite also has App versions of its software to complement their desktop counterparts.

# Windows File Management

Windows saves data in the form of a file. This file could be a photograph, eg, claire.jpg; a document, eg letterto claire.doc; a music track, eg demotrack.mp3, and so on.

Files are usually saved onto a hard disk. The hard disk drive is located inside the computer itself. This is called local storage.

Notice Windows distinguishes between file types using a 3 letter extension: doc for documents, jpg for photos, mp3 for music etc. This helps to organise different types of data.

You can view all the files on your computer using Windows File Explorer. Click the yellow icon on your taskbar. This is where you can organise files, delete files, copy files as well as view files.

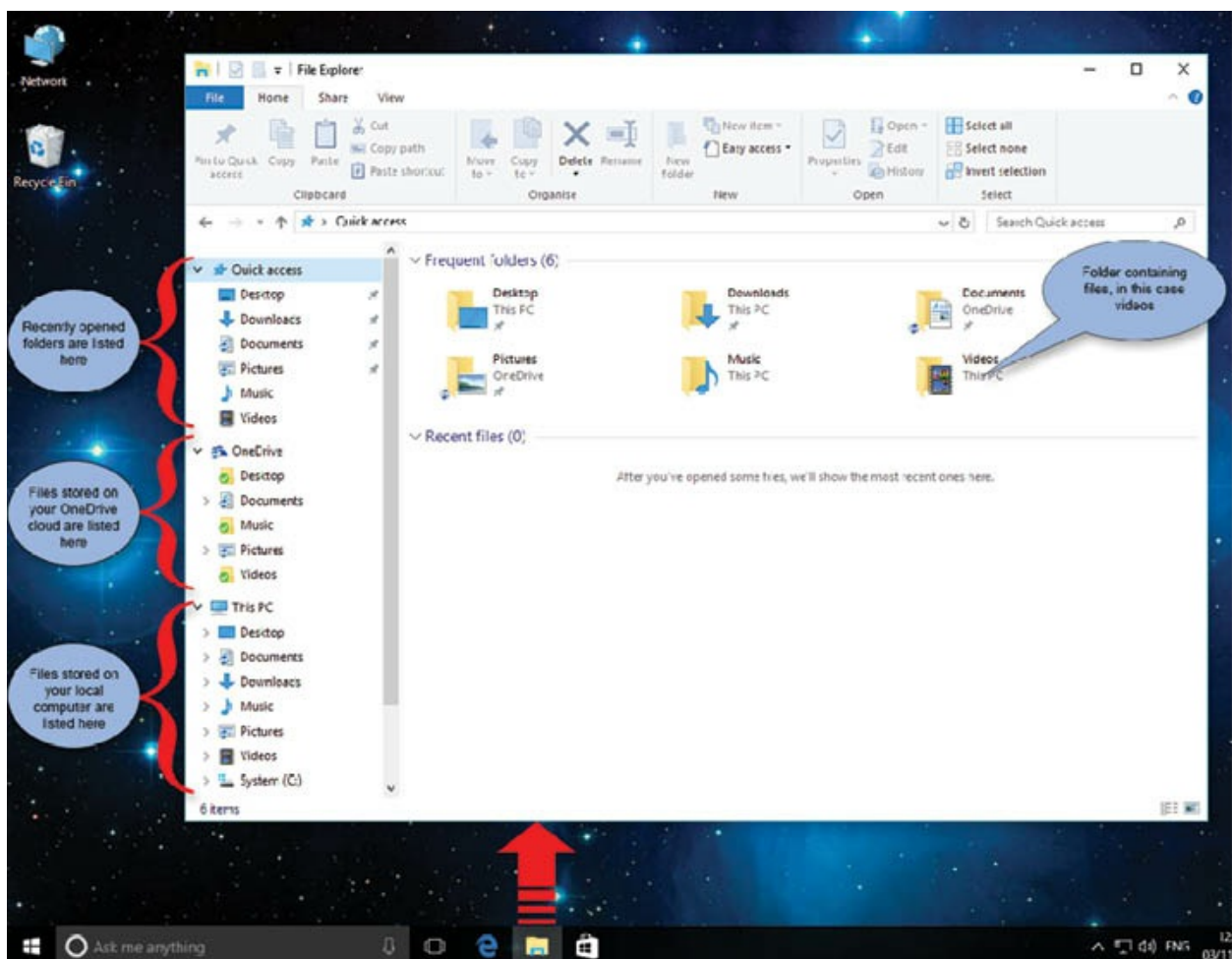



To keep files organised, Windows allows you to create folders to keep all your different types of files grouped together.

For example, the documents folder can contain letters, for eg letterto claire.doc. Your photographs, eg claire.jpg, can go in the pictures folder. Also, the demotrack.mp3 can go in the music folder, and so on.

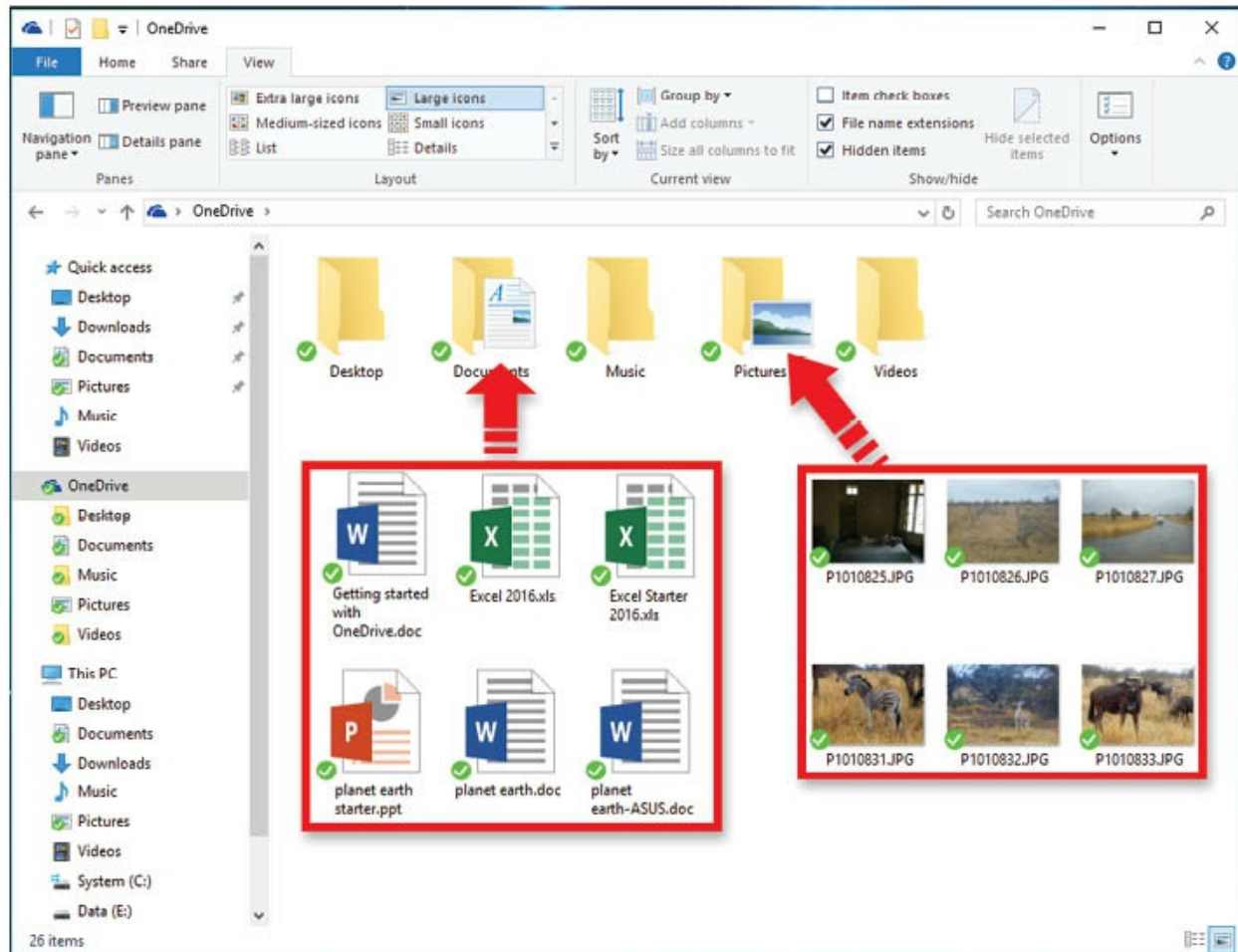

By doing this, you can easily organise your files and keep track of your work.

To make things easier to see, you can change how Windows shows your files. You can have them as lists, or large icons. To change this, click the view menu.

You'll see a section on the ribbon called 'layout'. Select one of these options. In this example, I have selected 'large icons' so everything appears nice and clear.

If you have photographs, you can select 'extra large icons', this will allow

you to see a thumbnail of the photograph instead of an icon.  
If you are in a folder with lots of documents, click 'details'.

# Creating Folders

You can create your own folders. To do this, open the folder you want to create your new folder in, right click in the empty space, and from the menu that appears, select 'new', then click 'folder'. An 'untitled' folder will appear in the window. Type in the name for your folder.

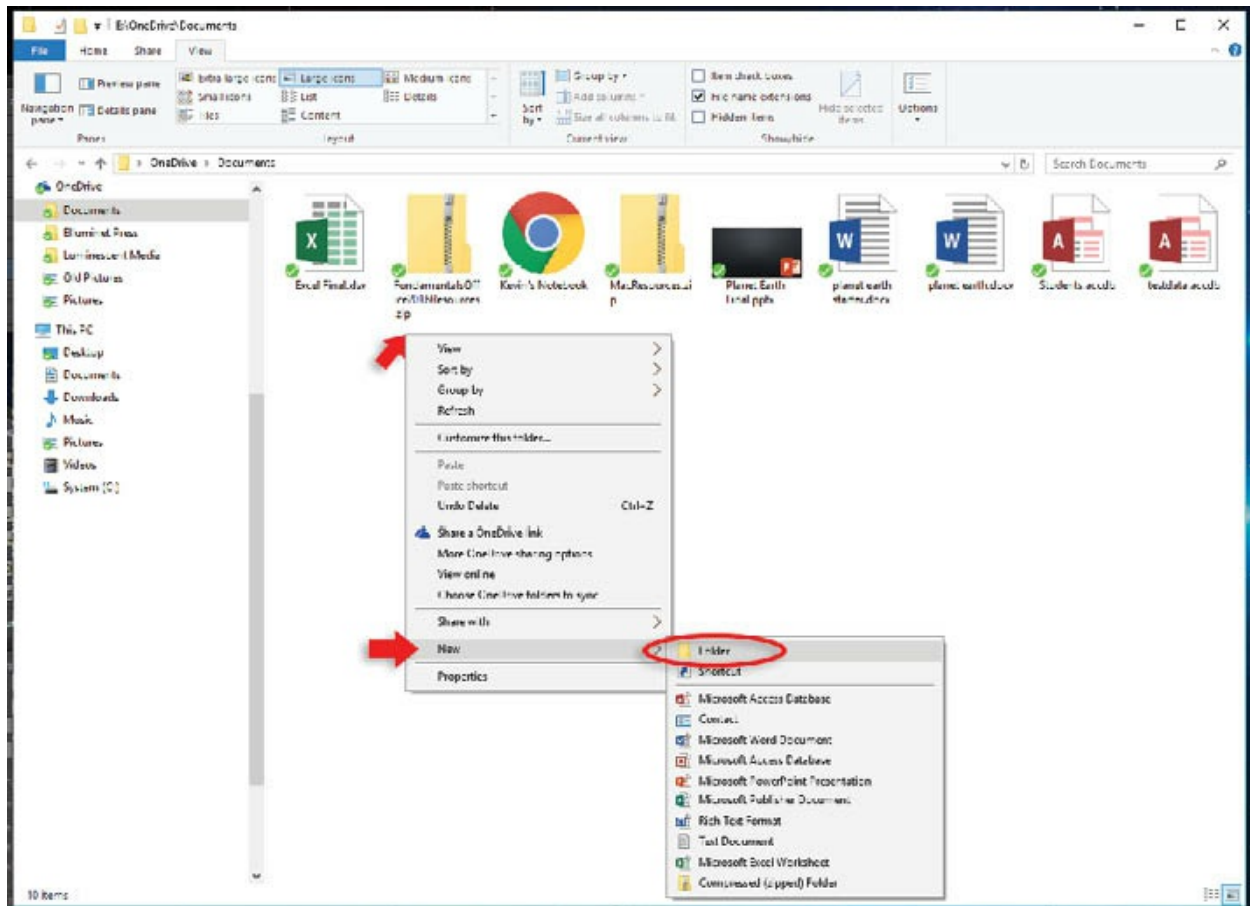

# Moving Files

To move files, click and drag then to the folder. To select multiple files at a time, hold down your control key (ctrl) while you click on your files to select.

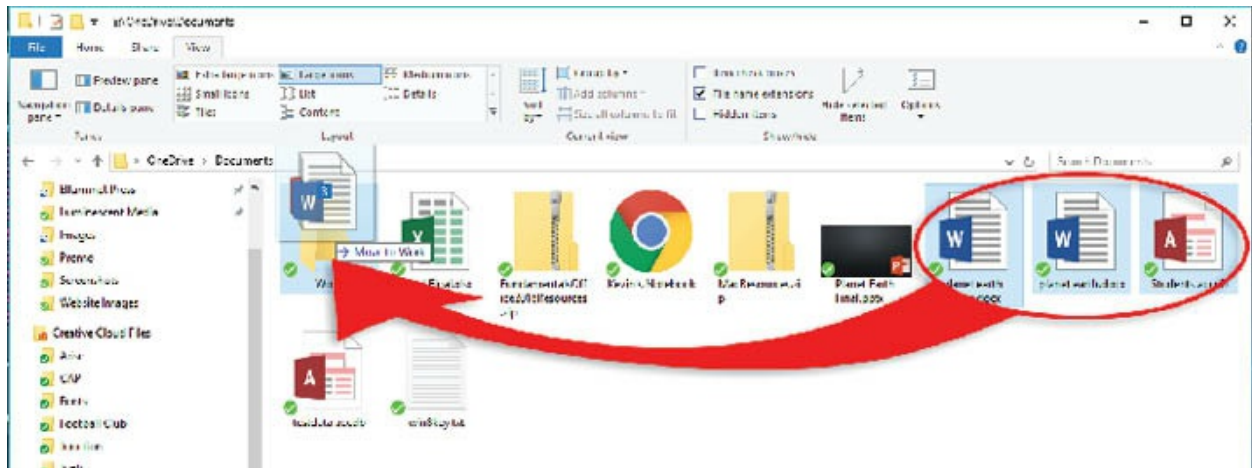

# Copying Files

To copy files, you need to use 'copy and paste'. Select the files you want to copy. Hold down your control (ctrl) key to select multiple files.

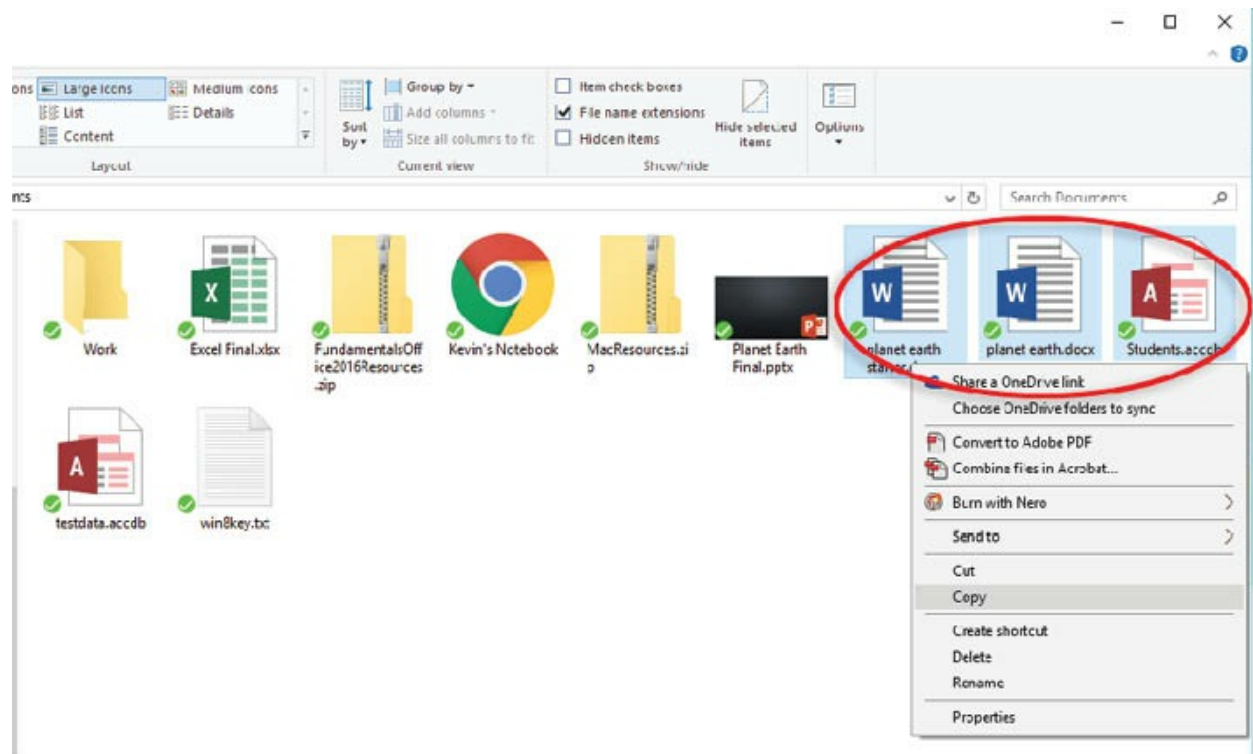

Now, open the folder you want to copy the files to. In this example, I am copying the selected files to the 'work' folder, so I will double click on the 'work' folder to open it up.

In the blank space, right click, and from the popup menu, select 'paste'.

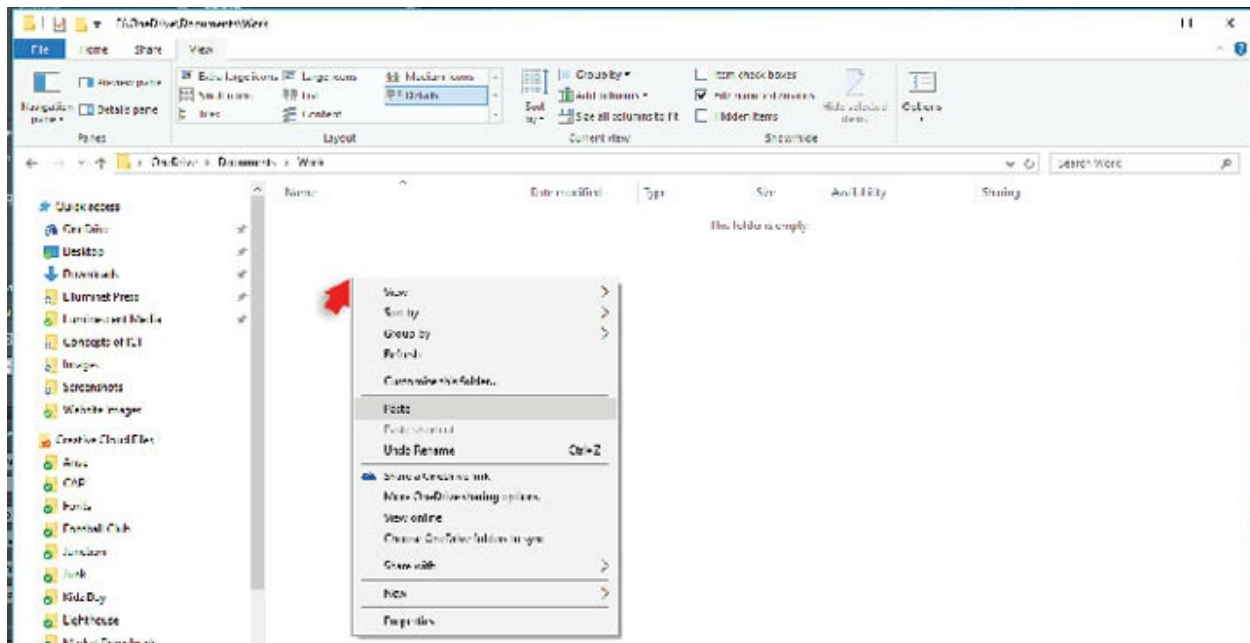

If files of the same name already exist, you'll get a prompt asking you to overwrite. If you select compare, keep the one with the latest date.

# Compress Files

You can compress files, sometimes referred to as zipping up files. To do this, select your files. Remember you can hold down your control (ctrl) key to select multiple files.

Right click on your selections and from the menu, go down to 'send to'. From the slide out menu, select 'compressed (zipped) folder'.

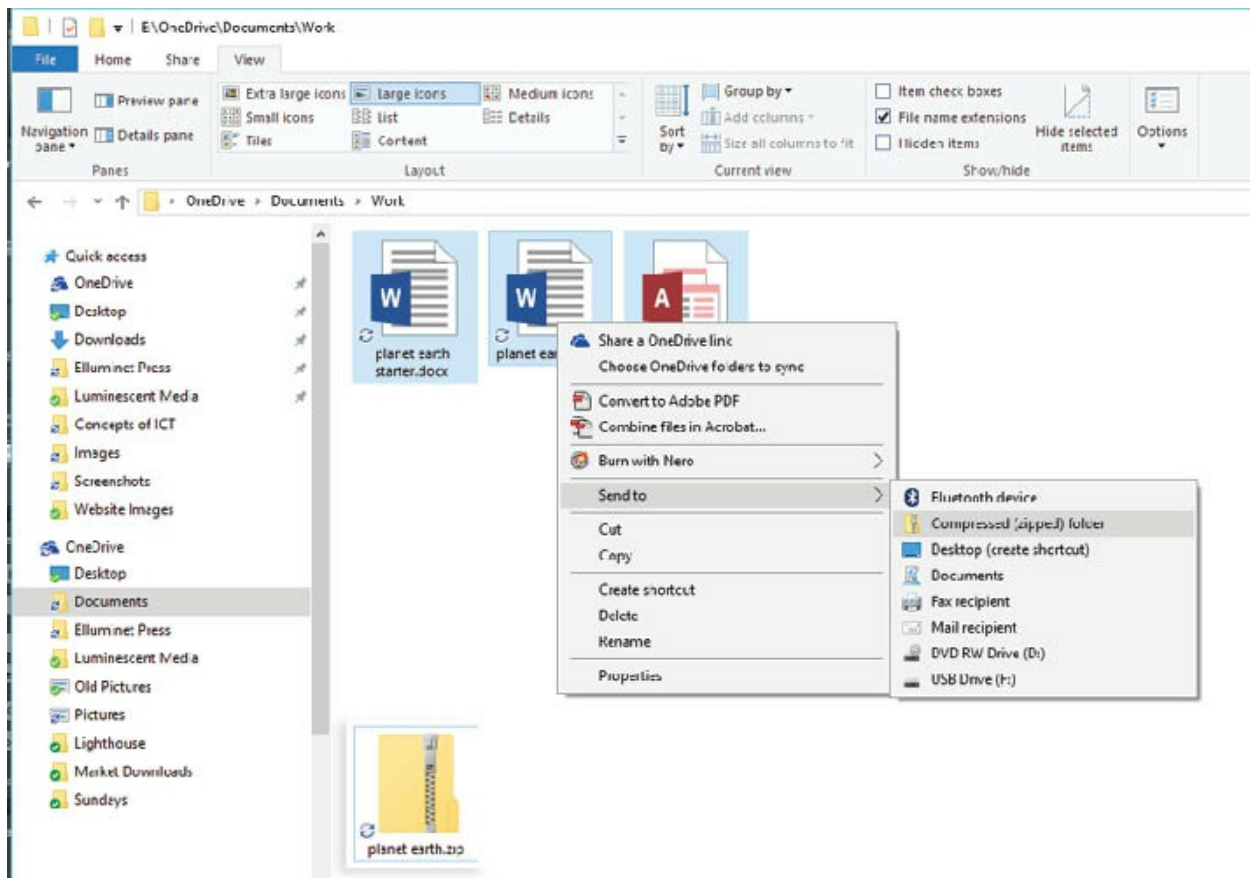

This will create a new file in your folder. In this example, 'planet earth.zip'. This is the file containing your compressed files.

You can open the compressed folder by double clicking on the icon.

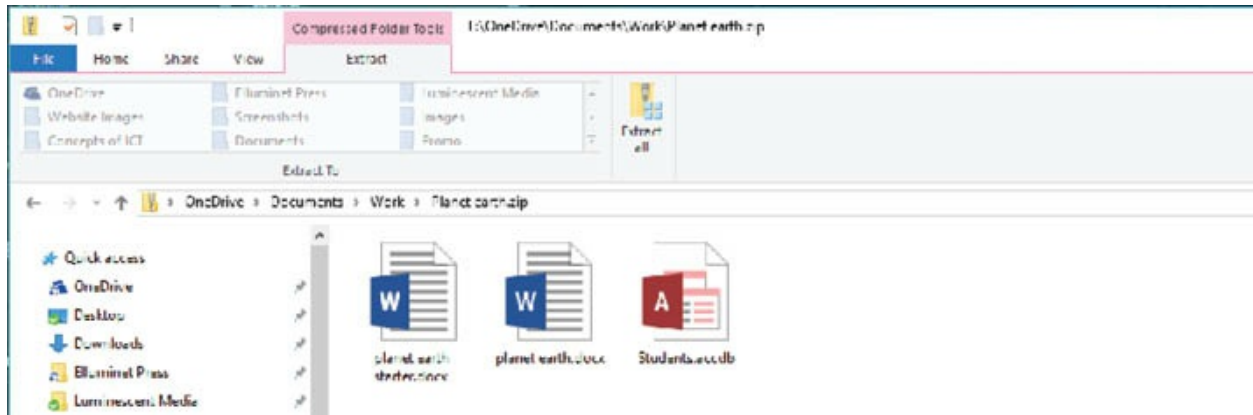



# Searching for Files

You can search for files in the folder you are in, if you type the name of the document in the search field, on the top right of your screen.

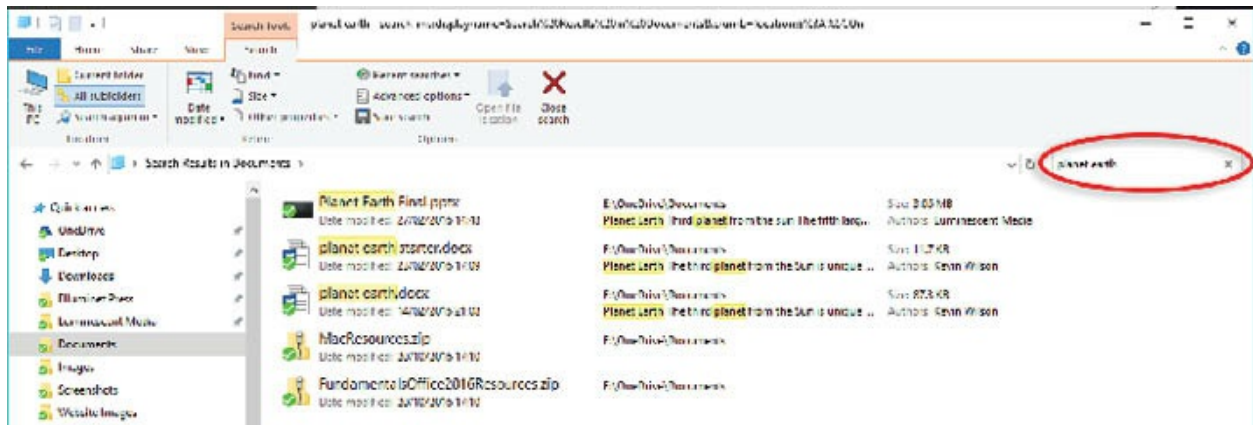

The search feature also scans inside files, so if you don't know what you called the file, type in a word or phrase of what the document was about.

You can also search your whole computer using the search field on the task bar. Type the document name into the search field. At the top of the box that appears, click the documents icon.

The image shows a OneDrive search results page. At the top, there are navigation icons for Home, Recent, and Search, along with a 'More' dropdown menu. The search results are filtered to show 'Best matches for documents'. The top result is 'planet earth.docx', a Microsoft Word Document in Word, last modified on 05/03/2015. Below this, a list of documents is shown, including multiple instances of 'planet earth.docx' in various locations (Word, Documents, Downloads, Resources) and 'Planet Earth Final.pptx' and 'Planet Earth Starter.pptx' in Downloads and Resources. The search term 'planet earth' is circled in red at the bottom of the page.

Best matches for documents

**planet earth.docx**  
Microsoft Word Document in Word  
Last modified: 05/03/2015

**Documents**

- planet earth.docx - in Word
- planet earth.docx - in Word
- planet earth.docx - in Word
- planet earth.docx - in Documents
- Planet Earth Final.docx - in Downloads
- Planet Earth Final.pptx - in Documents
- Planet Earth Final.pptx - in Public
- Planet Earth Final.docx - in Resources
- Planet Earth Final.docx - in Resources
- Planet Earth Final.pptx - in Resources
- Planet Earth Final.pptx - in Resources
- Planet Earth Starter (1).docx
- Planet Earth Starter.pptx - in Downloads
- Planet Earth Starter.docx - in Downloads

planet earth

# **System Maintenance**

Computer maintenance keeps your computer in a good working order.

# **Anti-Virus Software**

A lot of this software is sold pre-installed on the machine you buy and is offered on a subscription basis. So you have to pay to update the software. There are some however that are available for free to home users.

# Windows Defender

Windows 10 comes pre-installed with Windows Defender which is automatically updated by Microsoft for free.

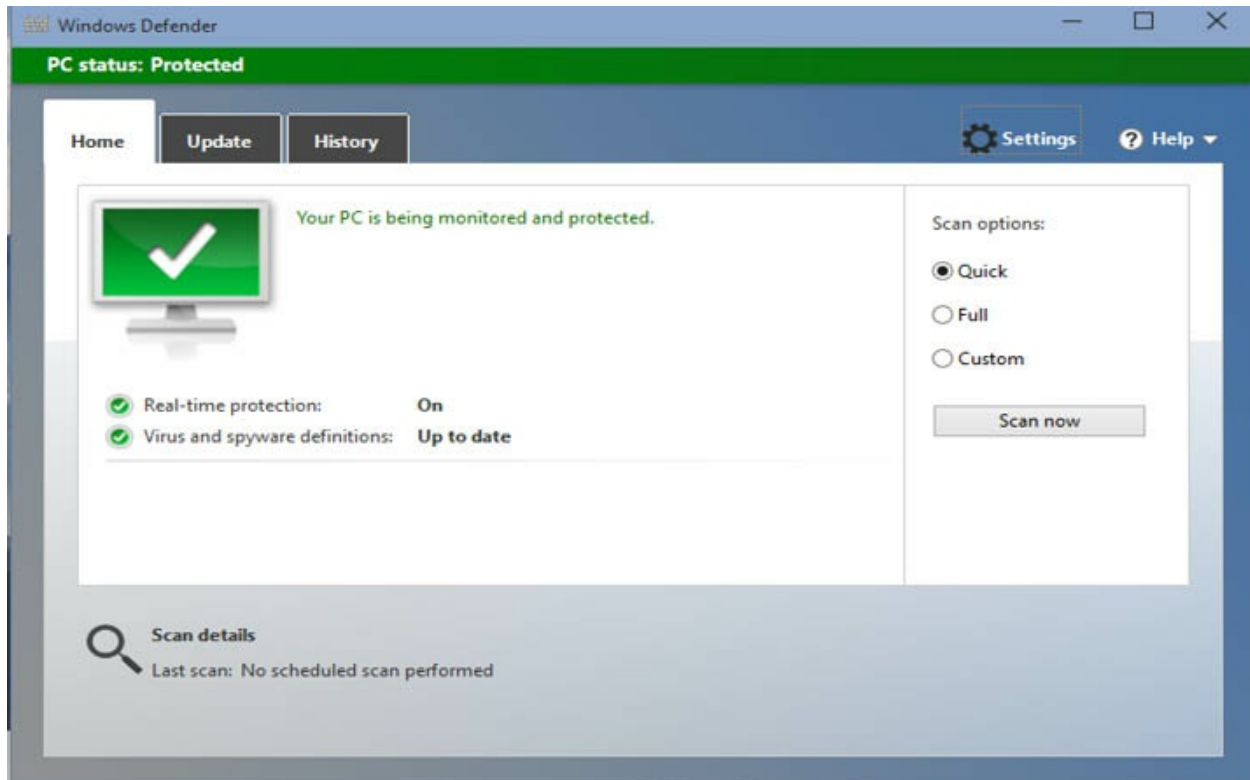

This is the bare essentials and is the minimum protection against viruses and online threats. This is adequate if you just browse the web and check your email. If you do online banking or shop online, then you should have a look at some of the more advanced security software packages.

Two free ones that are a good place to start are Avast and AVG. Both of these packages are very good. The free one is basic, but you can upgrade if you need something more.

# Avast

Avast scans and detects vulnerabilities in your home network, checks for program updates, scans files as you open them, emails as they come in and fixes PC performance issues.

You can download it from their website.

[www.avast.com](http://www.avast.com)

Scroll down the page until you find 'free download'.

	FREE DOWNLOAD	DOWNLOAD Free 30-day trial	DOWNLOAD Free 30-day trial
<b>Intelligent antivirus &amp; anti-malware</b> Detects threats no one has even heard of yet.	•	•	•
<b>Home Network Security</b> Scan your home network for weak spots.	•	•	•
<b>Browser Cleanup</b> Get rid of annoying browser add-ons.	•	•	•
<b>Pay &amp; bank online. Safely.</b> Prevent your logins and passwords from theft.		•	•
<b>Anti-hijack protection</b> Log in to your real banking site, not a fake one.		•	•
<b>Silent Firewall</b> Shield your computer from hackers.		•	•
<b>Anti-spam</b> Keeping your inbox junk-free feels good.		•	•

3000-2239 4-10019223.html?part=dl-85737&subj=dl&taq=button

The other two versions here are 30 day trials and will expire after 30 days. You will need to pay a subscription to continue.

When prompted hit 'install'. If the installation doesn't run automatically, go to your downloads folder and run 'avast\_free\_antivirus\_setup.exe', follow the on screen wizard.

# AVG

AVG blocks viruses, spyware, & other malware, scans web, twitter, & facebook links and warns you of malicious attachments.

You can download it from their website.

[www.avg.com](http://www.avg.com)

Compare Products | Features | System Requirements

## Or choose what's best for you

	AntiVirus FREE 2015	AntiVirus 2015	Internet Security 2015
<b>Antivirus</b> Blocks viruses, spyware, & other malware	✓	✓	✓
<b>Link Protection</b> Scans web, Twitter®, & Facebook® links	✓	✓	✓
<b>Email Protection</b> Warns you of malicious attachments	•	✓	✓
<b>Online Shield</b> Protects you from harmful downloads	•	✓	✓
<b>Data Safe</b> Encrypts & password-protects private files	•	✓	✓
<b>More Frequent Auto-Updates</b> Get automatic security updates every 2 hours	•	✓	✓
<b>Anti-Spam</b> Keep your inbox free of spam & scams	•	•	✓
<b>Shopping Protection</b> Shop & bank safer with Enhanced Firewall	•	•	✓

**100%** Money-Back Guarantee  
Buy without risk! If you're not satisfied in the first 30 days, we'll refund your money. [Learn more](#)

**FREE Download** | **FREE Trial** | **FREE Trial**

[Buy Now](#) | [Buy Now](#)

The other two versions here are 30 day trials and will expire after 30 days. You will need to pay a subscription to continue.

# Backing Up your Files

If you have ever lost data because of a computer glitch or crash you know how frustrating it can be. So we all need a good backup strategy. I'm going to go through the strategy I have found that has worked well over the years.

First of all go buy yourself a good external hard disk. This is a small device that plugs into a USB port on your computer. Below is a typical specification for an external hard disk



Plug in your external drive into a free USB port.

In the search field on the task bar type 'file history'



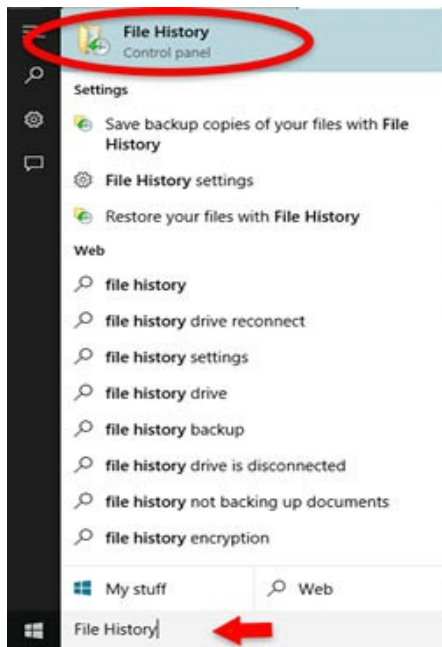

Click 'File History' circled above

On the screen that appears, click 'Turn On' to enable File History

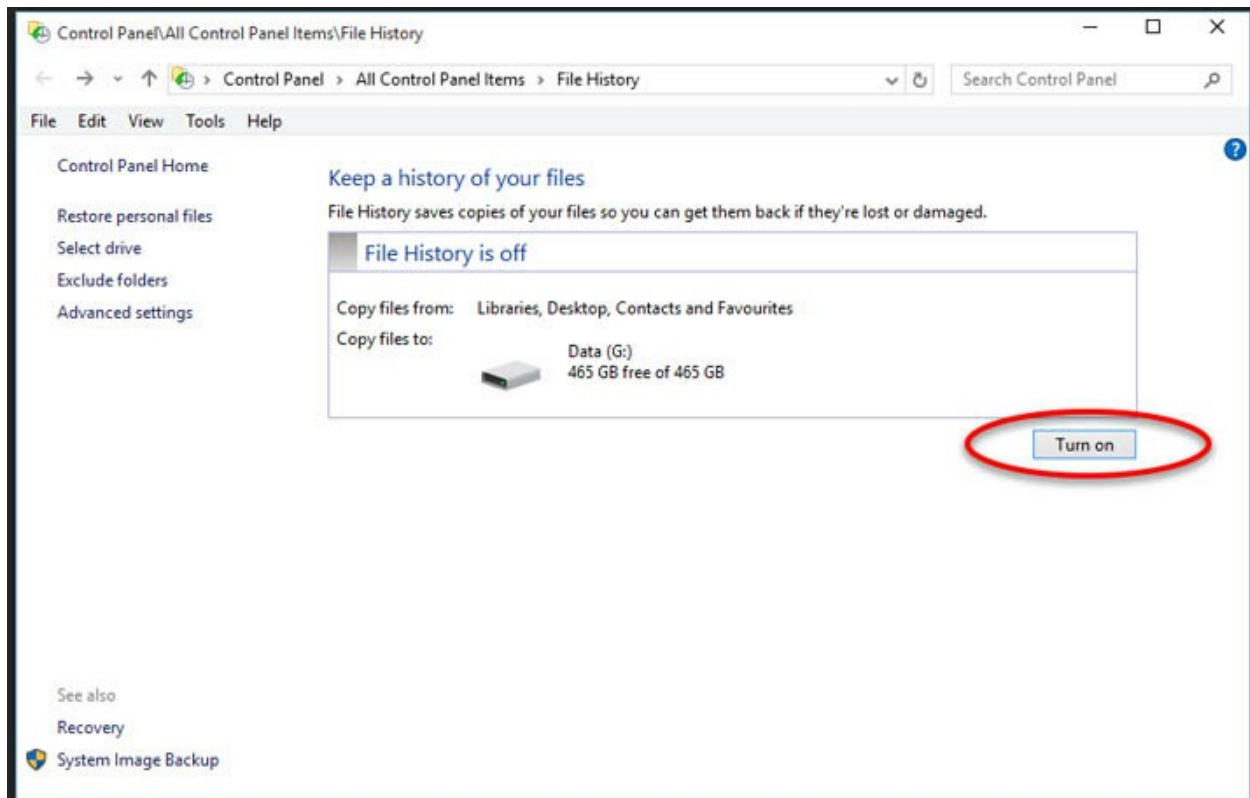

Once you have turned on File History, Windows 10 will start to copy files from your libraries (documents, pictures, music etc) onto your external hard

drive.

By default File History saves files every hour but you can change this by clicking on “Advanced Settings” listed down the left hand side of the screen.

A good guide is to set how often File History saves files to “Daily”. This will tell File History to save copies of your files once a day.

Good practice would be to plug in your external drive at the end of each day to back up what you have done throughout the day.

Backups can take a while depending on how much you have done.

# Restoring Files

Plug in your external Hard drive. Open up File History and click 'Restore Personal Files'

Use the left and right arrows at the bottom to navigate to the date backed up when you know your file still existed or was working.

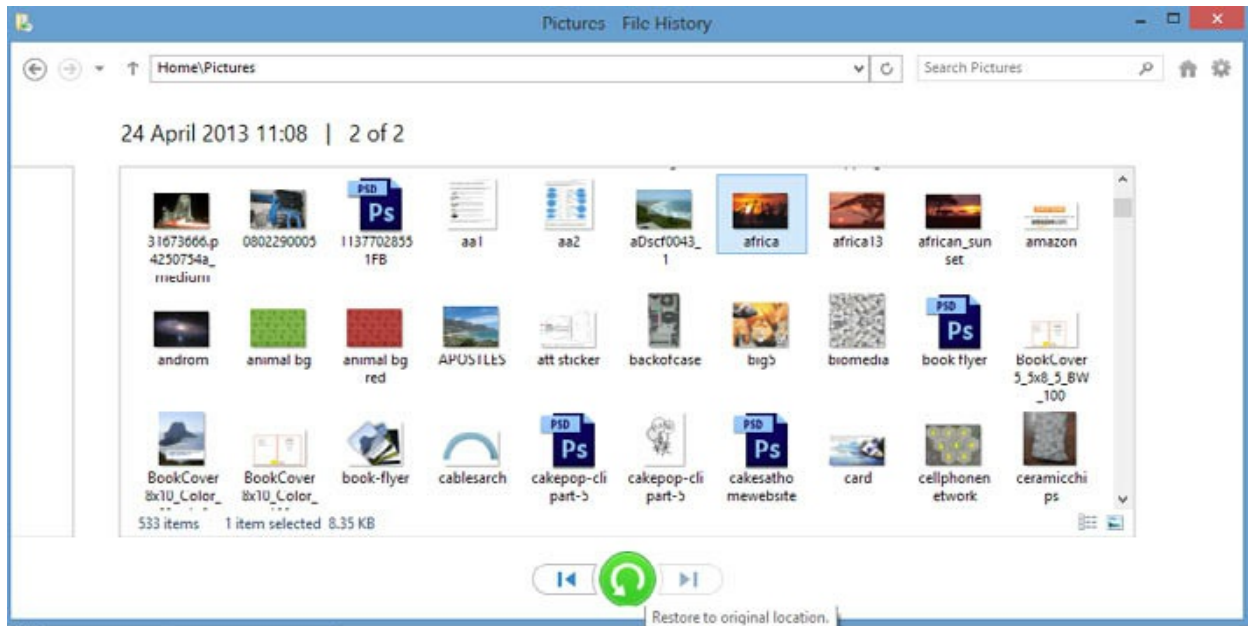

Then in the library section double click in the folder the file was in eg pictures if you lost a photo.

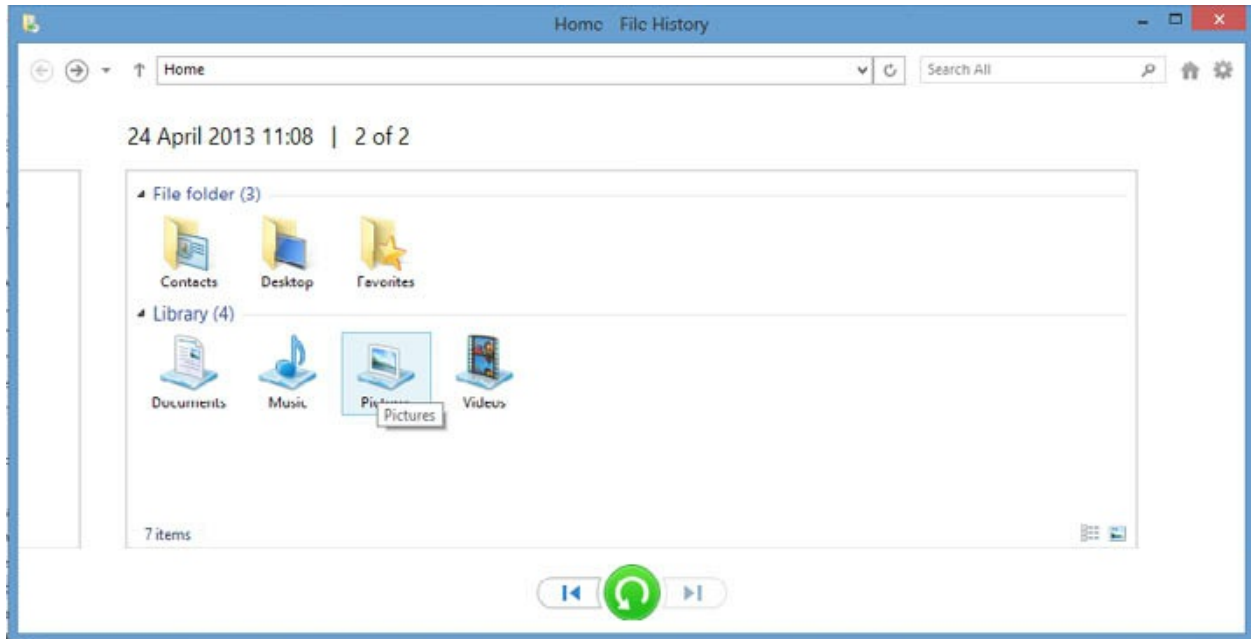

Select the photo and to restore it click the green button at the bottom of the window.

# Windows Update

Windows update usually automatically downloads and installs all updates available for windows

This automatic installation can sometimes be a nuisance if you are working and windows wants to download and install updates all the time. You can set it to manual install so you can decide when to install updates. If you don't want to worry about I would leave it on auto.

If you want to change the settings, click settings on the start menu.

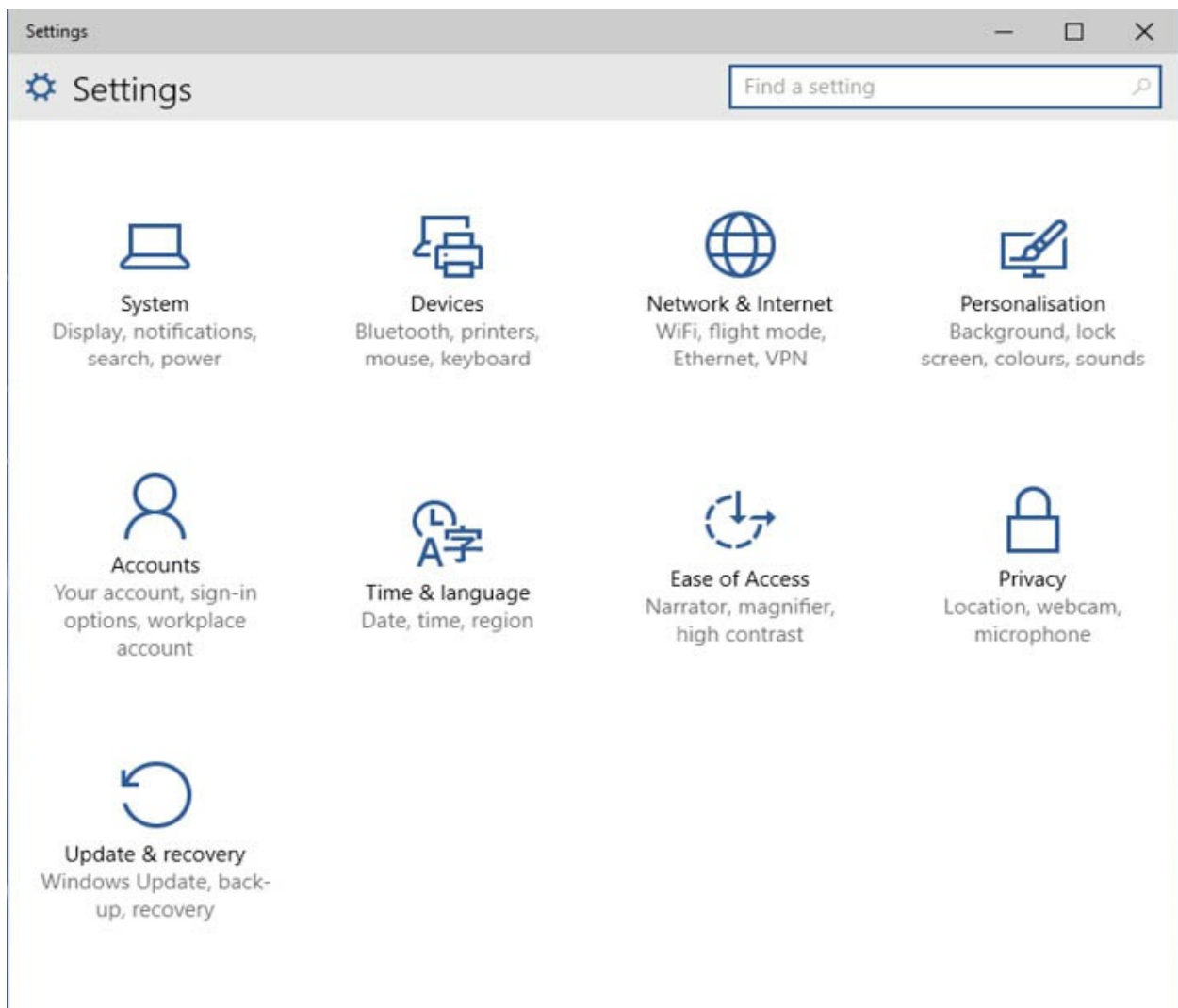

Select 'update & recovery', then select 'Advanced Options'

To prevent windows automatically installing updates select 'download

updates but let me choose whether to install them'

Windows will now download all available updates but it will ask you when it's convenient to install them.

# Disk De-fragmentation

Data is saved in blocks on the surface of the disk called clusters. When a computer saves your file, it writes the data to the next empty cluster on the disk, even if the clusters are not adjacent.

This allows faster performance, and usually, the disk is spinning fast enough that this has little effect on the time it takes to open the file.

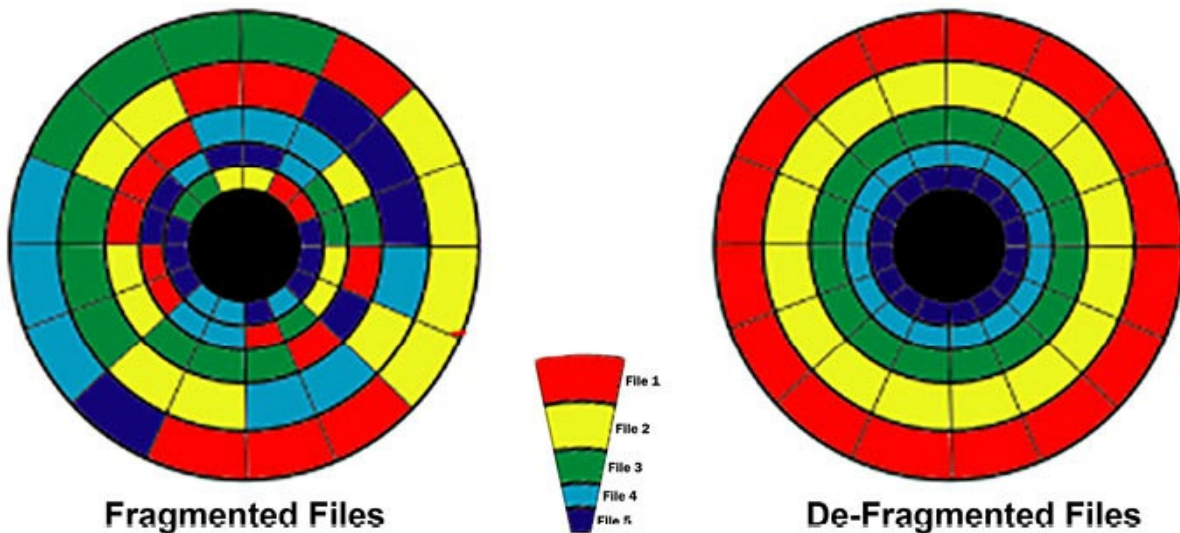

However, as more and more files are created, saved, deleted or changed, the data becomes fragmented across the surface of a disk, and it takes longer to access.

This can cause problems when launching software (because it will often load many different files as it launches). So bad fragmentation just makes every operation on the computer take longer but eventually fragmentation can cause applications to crash, hang, or even corrupt the data.

It's a good rule of thumb to do this roughly once a month, to keep things running smoothly.

To de-fragment the disk in Windows 10, activate the search and type 'defragment'. Click 'Defragment and optimise your drives'.

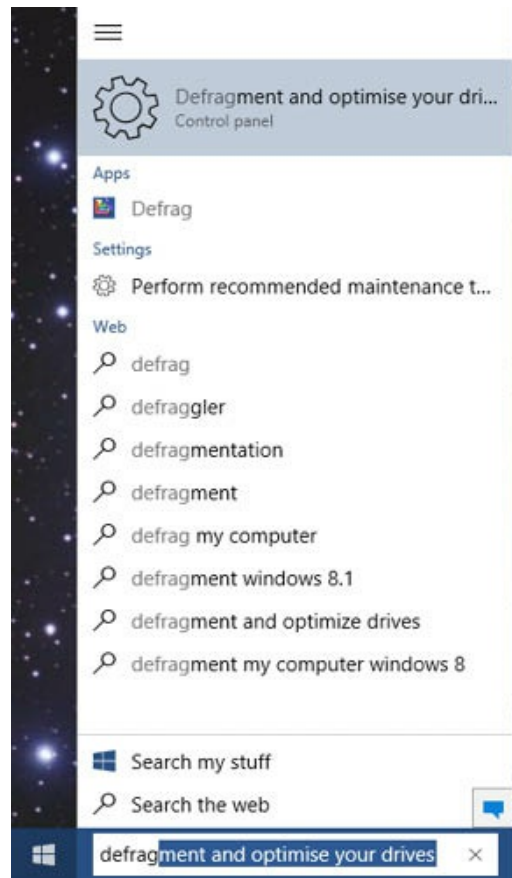

Select the drive your system is installed on, this is usually C. Click optimize

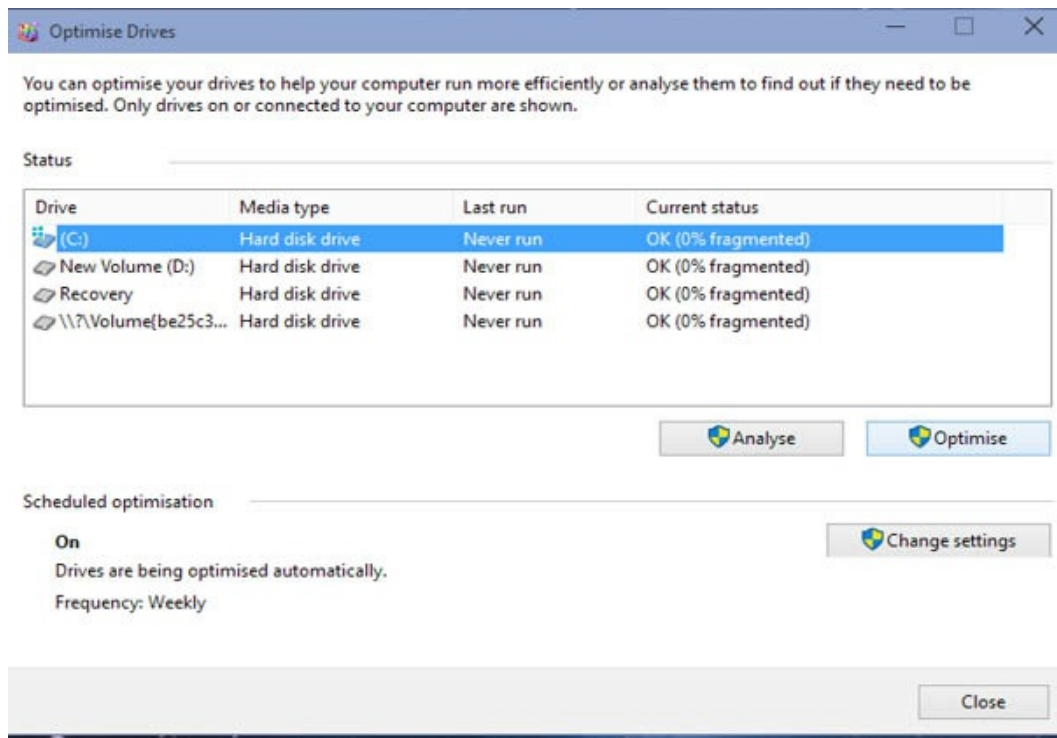



This will start de-fragmenting your disk. This process can take a while.

# Disk Clean-Up

Over time, windows gets clogged up with temporary files from browsing the internet, installing and un-installing software and general every day usage. Doing this once a month will help keep things running smoothly.

Using the search on the taskbar, type 'cleanup'.

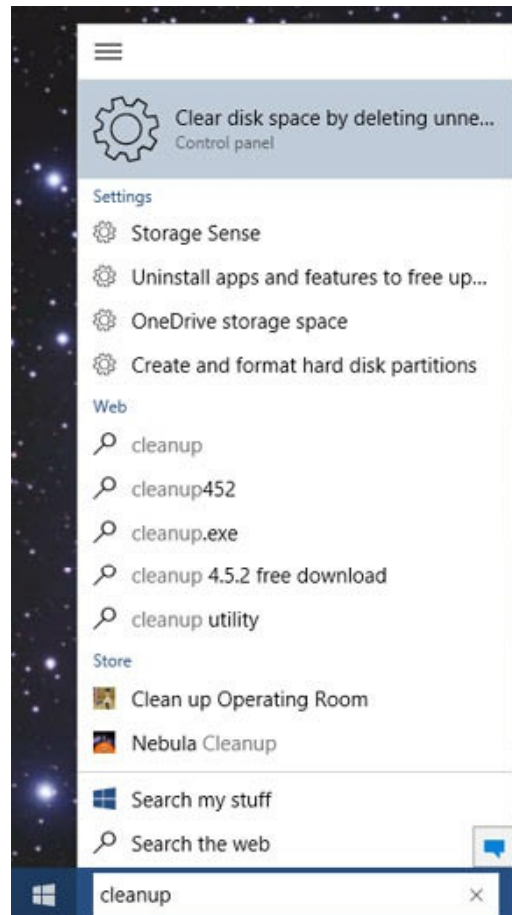

Click 'clear disk space by deleting unnecessary files'

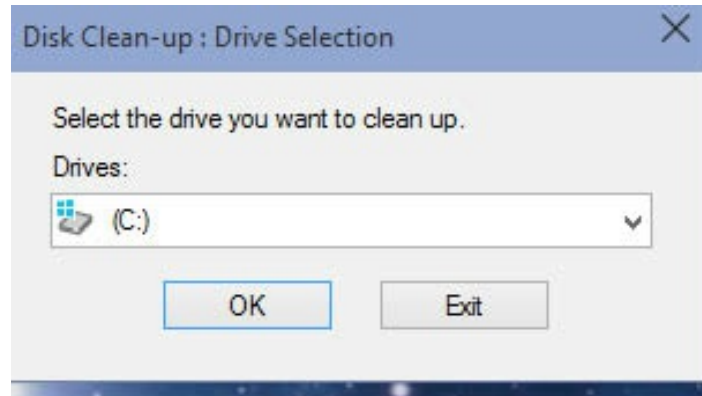

Select drive C, click ok.

In the window that appears you can see a list of all the different files and caches. It is safe to select all these for clearing.

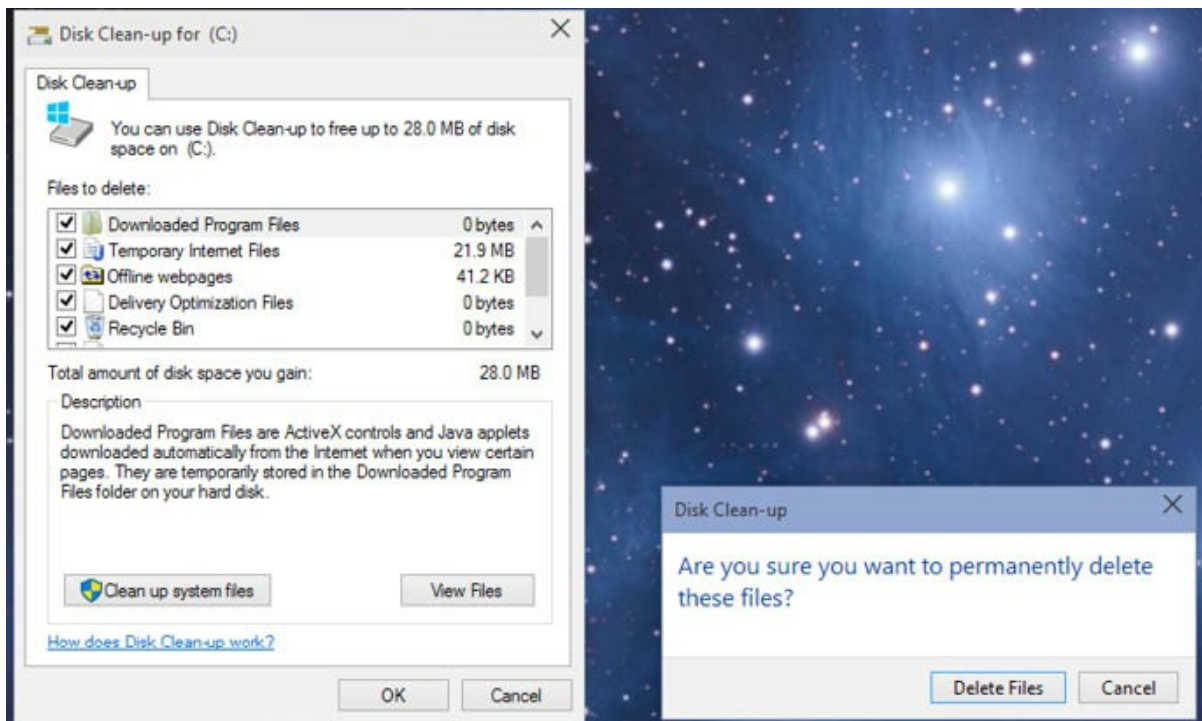

Once you are done click ok and windows will clear out all those old files.

Do the same with the system files. In the window above, click 'clean up system files'. This helps to keep your system running smoothly. A good rule of thumb is to do this about once a month.

# Start-Up Programs

Hit control-alt-delete on your keyboard and select task manager from the menu. Click more details if you don't have the screen below.

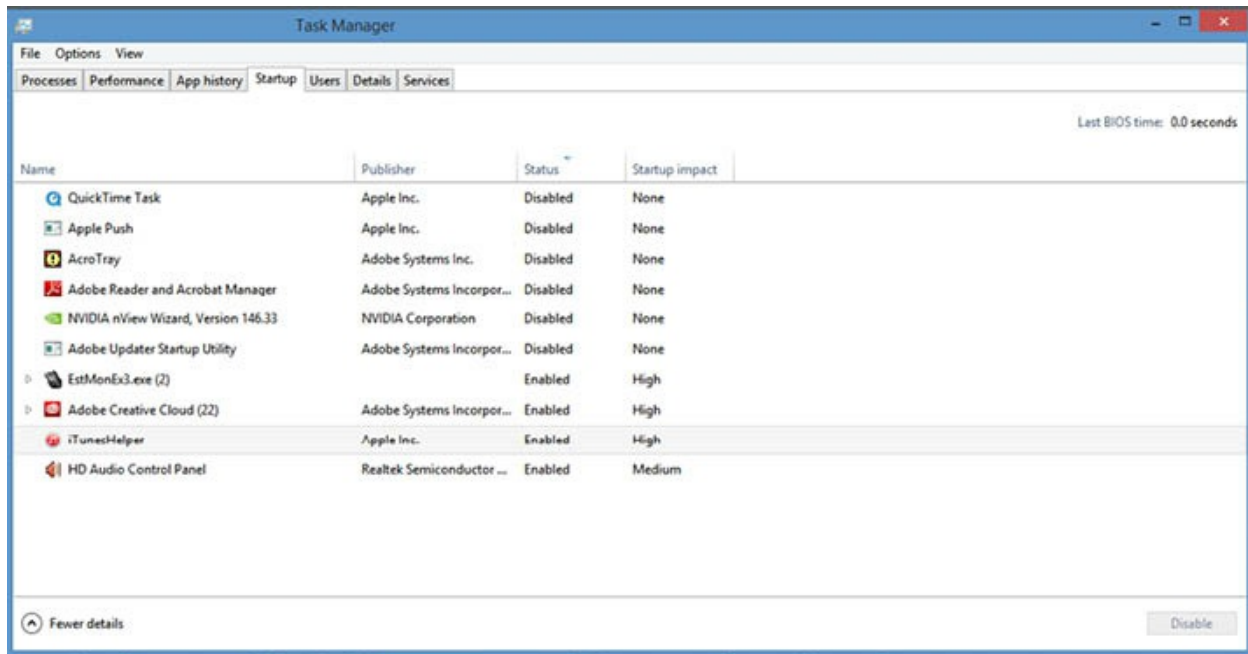

Click on the startup tab. Most of these programs can be disabled with the exception of your sound, video and network devices.

You will also see the startup impact this shows how much the program slows the machine down. These are the programs that show up in your system tray on the bottom right hand side of your screen. As you can see above, this system is quite clean – only essential icons appear in the tray.

If you are using a touch device you can access Task Manager by tapping the Search option on the start screen and type Task Manager. Then tap Task Manager in the list that appears.

# Remove Programs and Apps

There are two ways you can remove programs, through the control panel or directly from the start menu.

For desktop apps such as anti-virus software, Microsoft Office, Adobe Creative Suite and similar apps, you should remove these from the 'programs and features' section of the Control Panel.

As an example, I am going to remove 'avast antivirus' from my computer.

First you need to open the 'programs and features' section of the control panel. The quickest way to do this, is to search for it using the search field on the bottom left of your task bar.

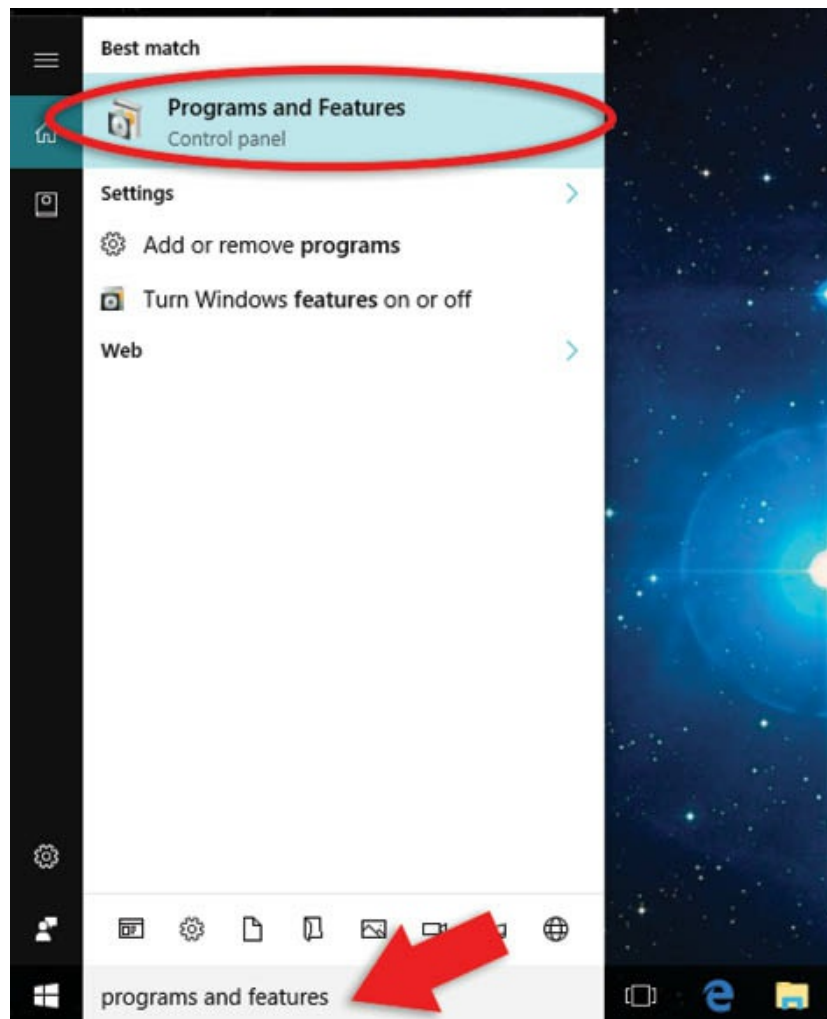

In the search field, indicated by the red arrow, type

programs and features

Click 'programs and features', circled above, from the search result.

Select the application you want to remove from the list, then click 'uninstall', circled below.

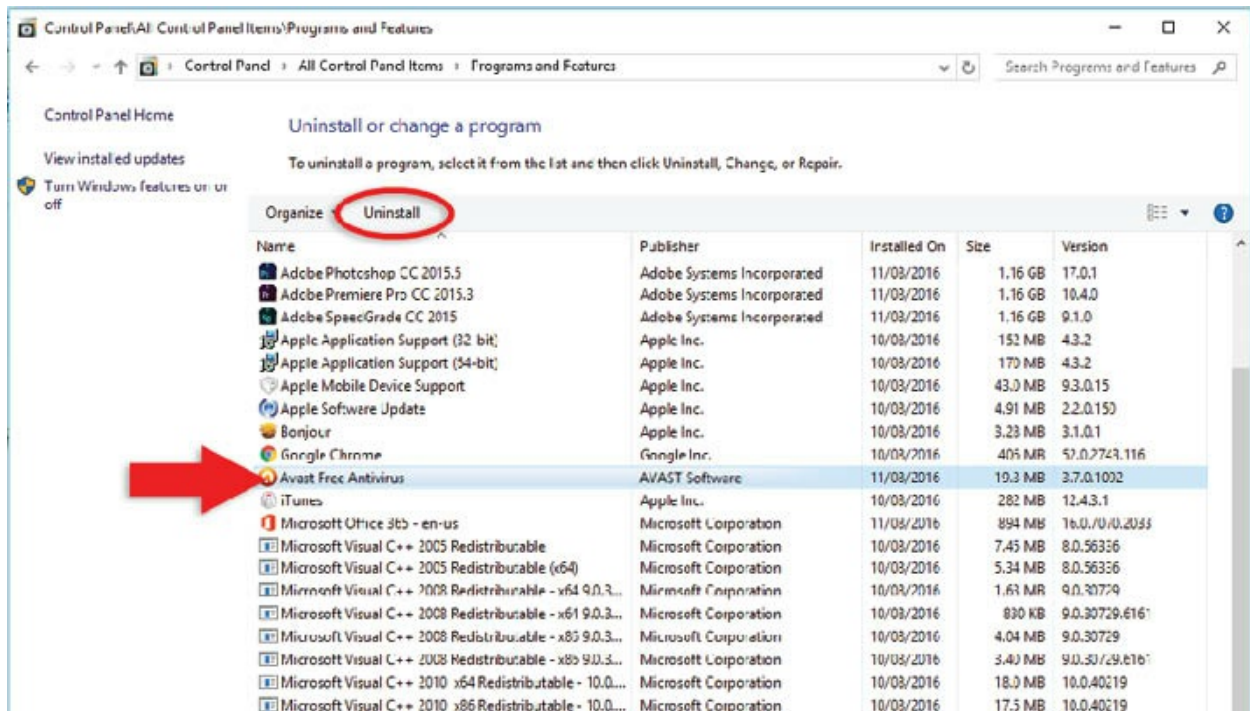

Now, depending on what program you are trying to remove, you might get a screen asking you what you want to do. In this case, avast is giving me options of what I can do.

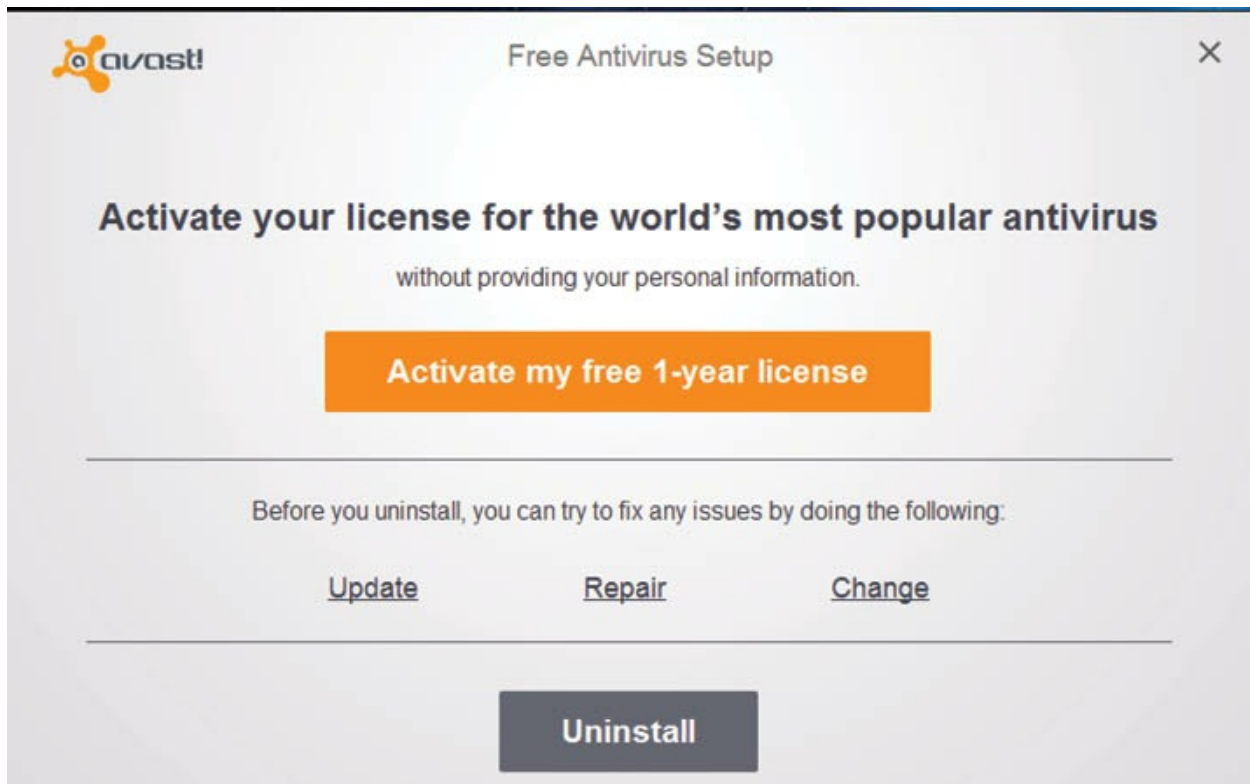

In most cases you just have to click the 'uninstall' button, also sometimes labelled 'remove'.

Once you have done that, the install wizard will run and start to remove the software you have chosen. Depending on what you have chosen to remove, you might need to restart your PC.

This is a similar process for removing old versions of Microsoft Office or Adobe Creative Suite and any other desktop applications.

It's good practice to go through the apps and programs installed on your device, and remove the ones you don't use anymore and any old apps. This helps to keep your device running smoothly.

For apps that you have downloaded from the App Store and ones that come with Windows 10, you can remove them directly from the start menu.

Do this by right clicking on the icon on the start menu and selecting 'uninstall'. Tap and hold your finger on the icon, if you are using a touch screen tablet.

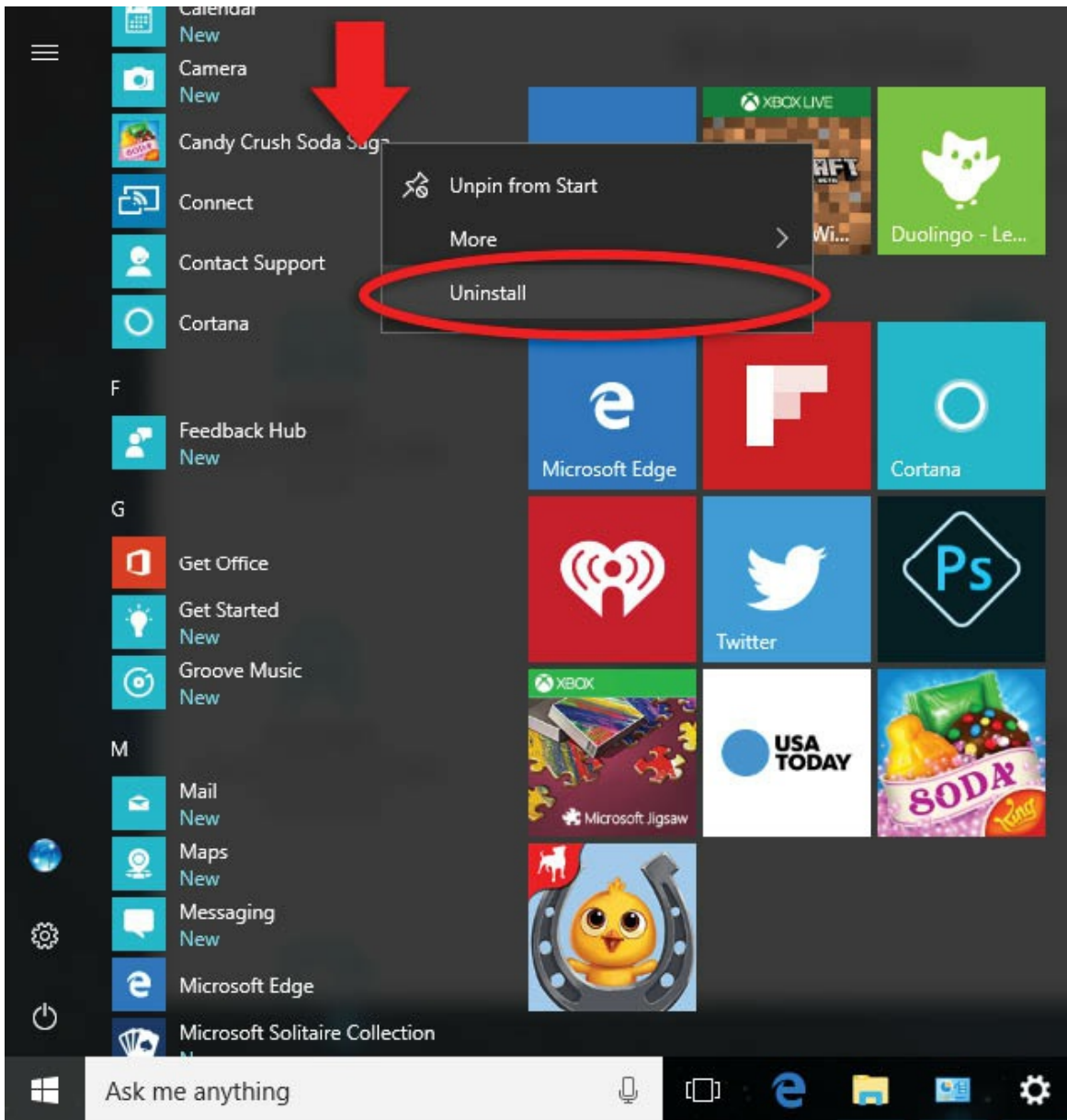

- Calendar New
- Camera New
- Candy Crush Soda Sugar
- Connect
- Contact Support
- Cortana
- F
- Feedback Hub New
- G
- Get Office
- Get Started New
- Groove Music New
- M
- Mail New
- Maps New
- Messaging New
- Microsoft Edge
- Microsoft Solitaire Collection

- Unpin from Start
- More >
- Uninstall

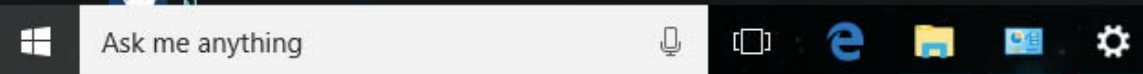
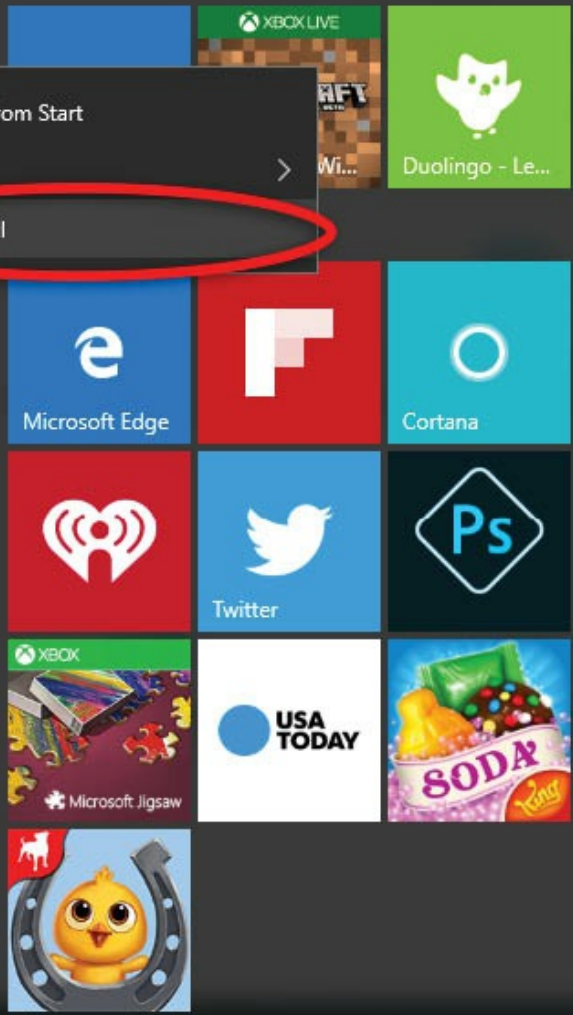



# System Recovery

If you are having problems then Windows 10 has a section to recover your computer.

Go to settings on your start menu.

Click update & security

Click 'restart now'

When your machine restarts, it will boot into recovery mode.

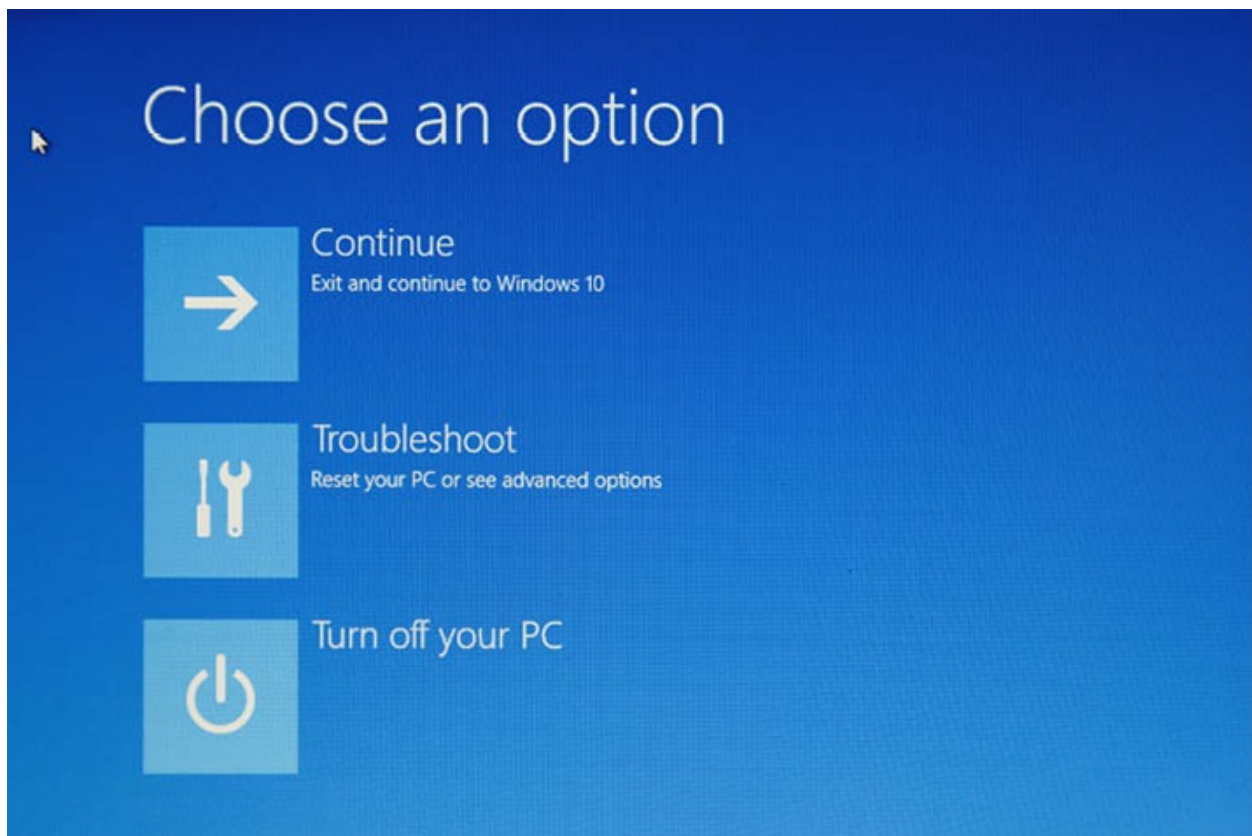

Clicking continue, will abort and return to windows 10.

Click 'troubleshoot' to enter recovery mode.

When in recovery mode you can click reset your PC.

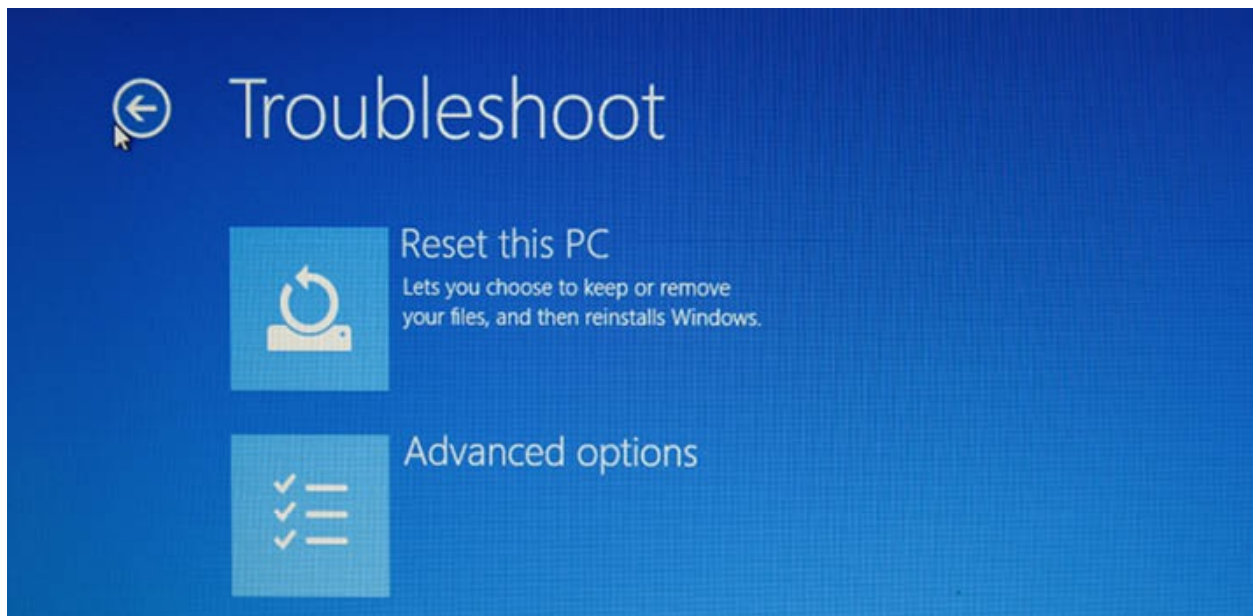

From here you can do a complete re-install by clicking on 'remove everything'. This will remove all your files and applications and reset Windows 10 back to its factory default.

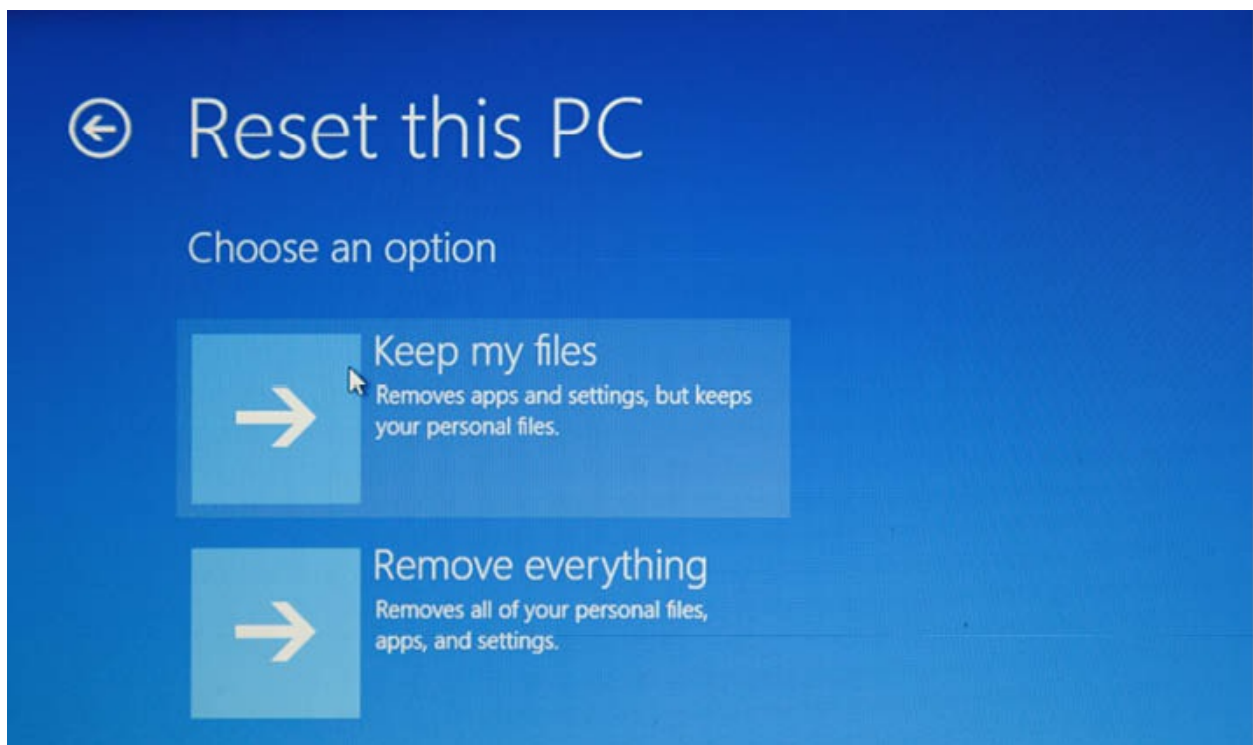

Clicking on 'keep my files', will refresh Windows 10, delete all your installed applications and settings. Your personal files and data will remain

intact.

# Advanced Start up

If you select 'Advanced Options' from the troubleshoot screen, there are a couple of useful features are 'system restore' which restores your PC to a previous state, for example if you installed a driver and its causing problems in windows.

Also 'System image recovery' if you created a recovery image disk. This can be used to restore windows from the image recovery disk.

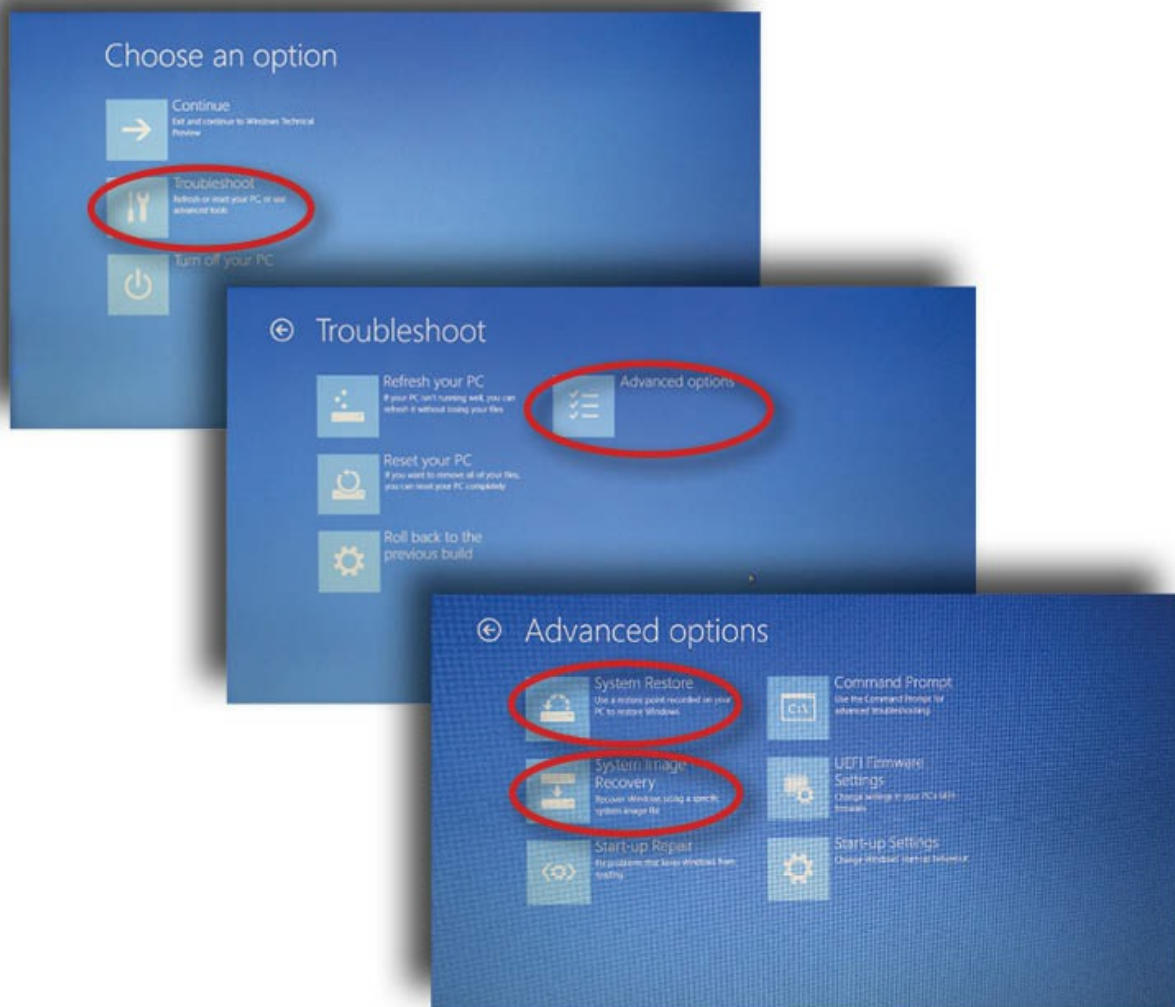

Insert your recovery disk and click 'system image recovery' to restore from a disk.

For information on creating images, see the next section.

# Create a Recovery Drive

A recovery drive or recovery disk is an exact copy of your entire system often referred to as a 'system image'. This image contains your operating system (windows 10), settings/preferences as well as any applications.

This is useful if your computer crashes and you can't start it up again.

From Cortana's Search type 'backup and restore'

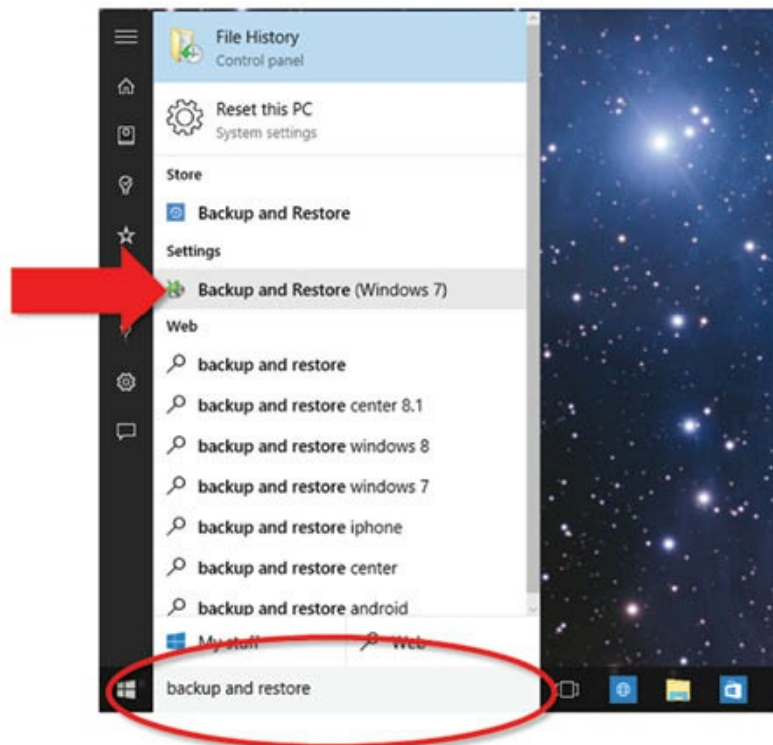

Plug in a portable hard drive (a 500GB capacity is usually enough)



Click 'Create a system image', then select "on a hard disk".

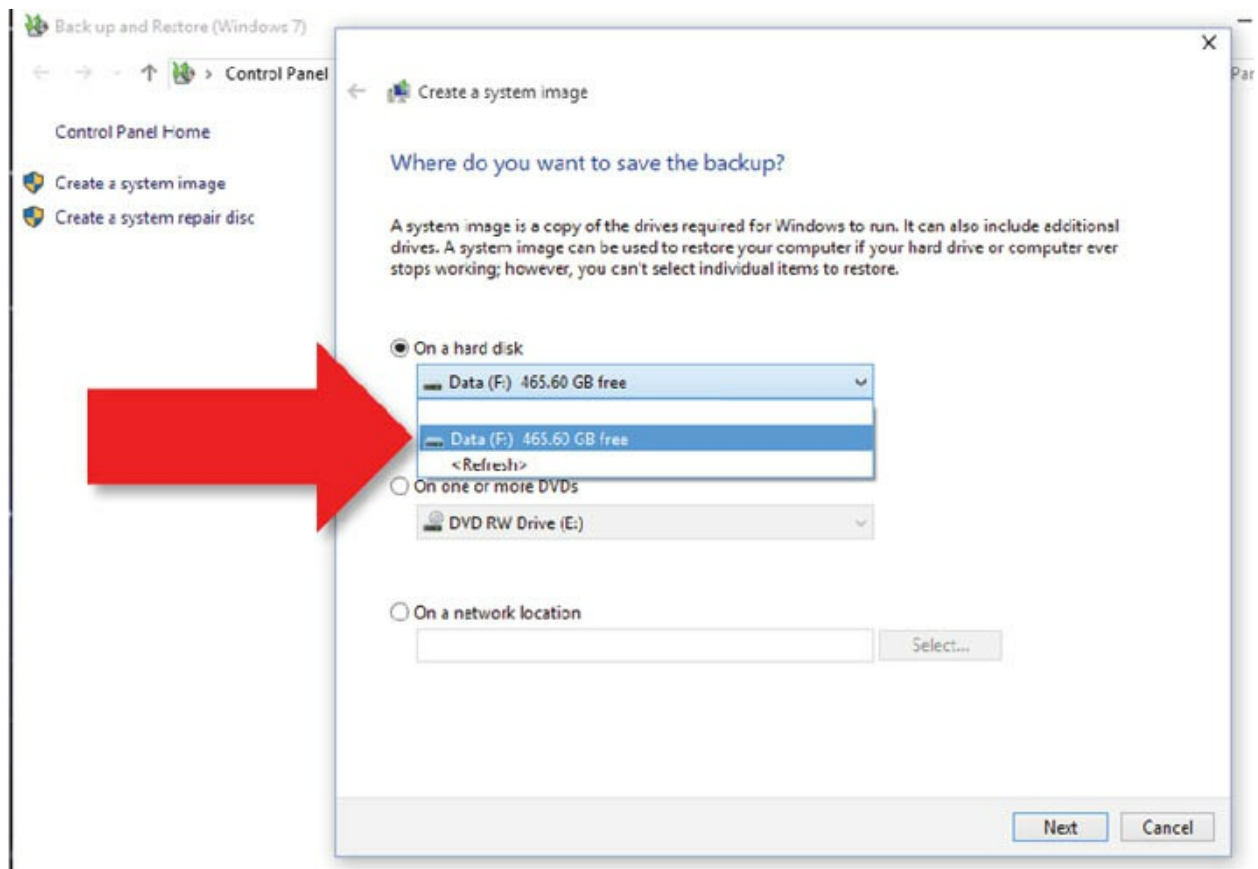

Click next. Make sure only 'system reserved', 'system' & 'windows recovery environment' is selected. Click next.

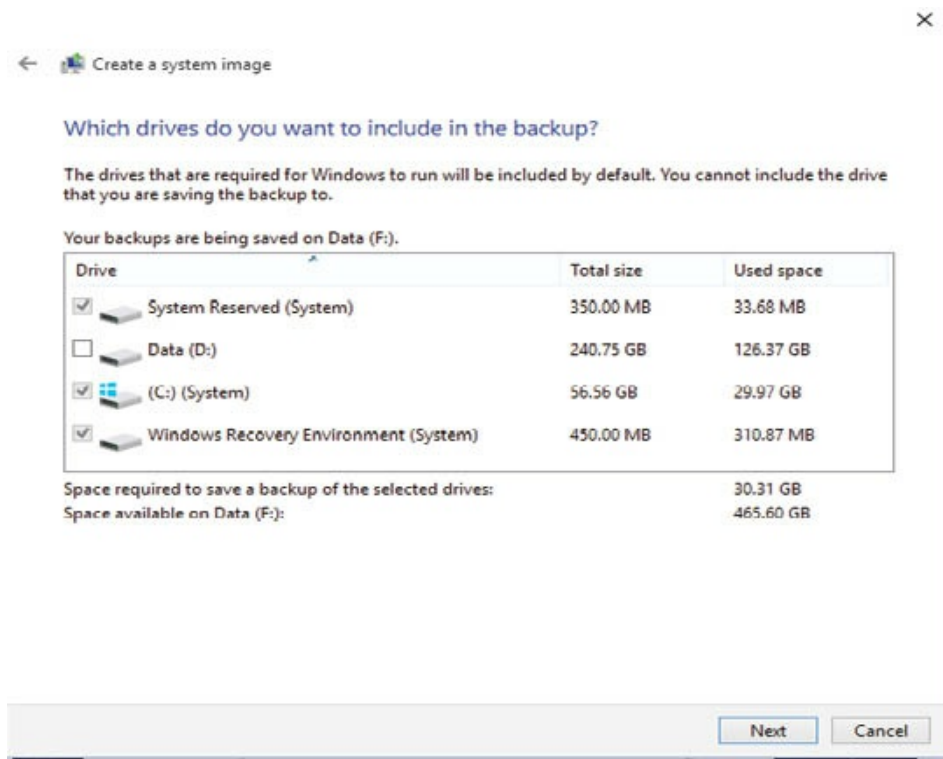

You will be able to start windows with this drive if your computer fails. Use the procedure outlined in 'advanced start up' in previous section.